

# Owner's Manual:

## 1400 & 1410 Classic

### One-Gallon Shaker

---

Models 1400-00, 1400-PB, 1400-DD, 1400-OH-E5,  
1410-PB, 1410-00, 1410-OH-E5, 1410-DD

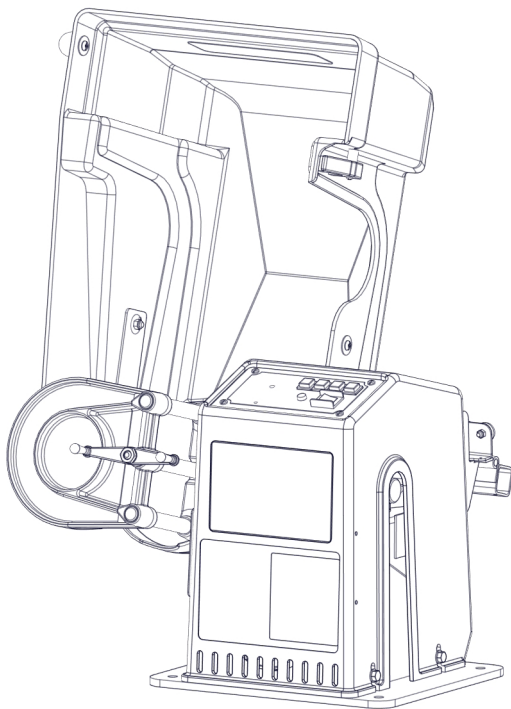

1410-PB

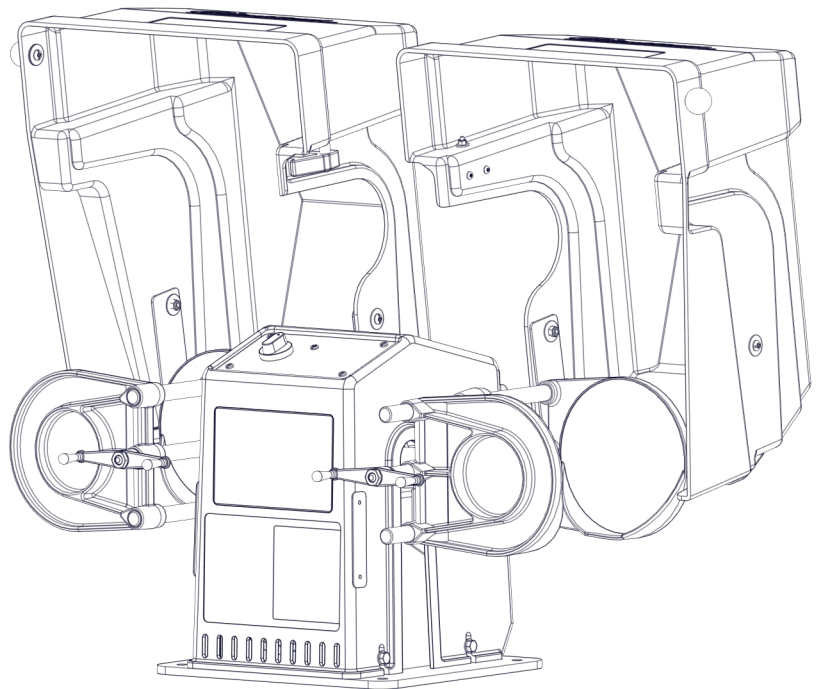

1400-00





# Table of Contents

<b>1. Safety Information</b>	<b>3</b>	<b>8. Exploded Views</b>	<b>19</b>
<a href="#">1.1 Safety Precaution Labels</a>	3-4	<a href="#">8.1 Drive System</a>	19
<a href="#">1.2 Safety Precaution Summary</a>	5	<a href="#">8.2 Transmission Assembly</a>	20
<b>2. Introduction</b>	<b>6</b>	<a href="#">8.3 Clamp Assembly, Left</a>	21
<a href="#">2.1 Application</a>	6	<a href="#">8.4 Camp Assembly, Right</a>	22
<a href="#">2.2 Specifications</a>	6-7	<a href="#">8.5 Enclosure Assembly</a>	23
<a href="#">2.3 Control Panel - Push Button Timer</a>	8	<a href="#">8.6 Clamp Cover Assembly</a>	24
<a href="#">2.3 Control Panel - Mechanical Timer</a>	8	<a href="#">8.7 Electrical Assembly PB</a>	25
<a href="#">2.3 Control Panel - Digital Display</a>	9	<a href="#">8.8 Electrical Assembly 00</a>	26
<a href="#">2.3 Control Panel - Digital Display Time Change</a>	10	<a href="#">8.9 Electrical Assembly OH</a>	27
<b>3. Assemble &amp; Test</b>	<b>11</b>	<a href="#">8.10 Electrical Assembly Digital Display</a>	28
<a href="#">3.1 Prepare for Use</a>	11	<a href="#">8.11 Counter Base</a>	29
<a href="#">3.2 Assemble the Counter Base</a>	11	<a href="#">8.12 Pedestal Base</a>	30
<a href="#">3.3 Assemble the Pedestal Base</a>	11-12	<b>9. Ordering</b>	<b>31</b>
<a href="#">3.4 Valve Cap Removal</a>	12	<a href="#">Replacement Parts</a>	31
<a href="#">3.5 Connect to Power</a>	12	<b>10. Warranty</b>	<b>32</b>
<b>4. Operation</b>	<b>13</b>	<b>11. Notes</b>	<b>33-34</b>
<a href="#">4.1 Install a Pail and Mix</a>	13		
<b>5. Care &amp; Maintenance</b>	<b>13</b>		
<a href="#">5.1 Cleaning</a>	13		
<a href="#">5.2 Maintenance</a>	13		
<b>6. <u>Trouble Shooting</u></b>	<b>14</b>		
<b>7. Wiring Diagram</b>	<b>15</b>		
<a href="#">7.1 1400/1410 - PB Models</a>	15		
<a href="#">7.2 1400/1410 - 00 and -OH Models</a>	16		
<a href="#">7.3 1400/1410 - DD</a>	17		
<a href="#">7.4 Internal Motor wiring for 120V/60 Hz and 220V / 50 Hz Models</a>	18		

# 1. Safety Information



**Review this owner's manual and read all warning labels on the machine prior to use.**

The three main safety notifications used in this manual and on the warning labels are **WARNING**, **CAUTION** and **NOTICE**. They have specific meanings and indicate the potential dangers from misuse of the machine.

	<p><b>“WARNING!”</b> indicates a hazardous situation, which, if not avoided, could result in death or serious injury. These serious injuries could include permanent loss of function or significant disfigurement, disability, considerable pain and suffering, amputations, severe burns, and loss or impairment of vision or hearing. Take all necessary precautions to avoid unnecessary injury.</p>
	<p><b>“CAUTION!”</b> indicates a hazardous situation, which, if not avoided, could result in minor or moderate injury.</p>
	<p><b>“NOTICE”</b> indicates practices that do not involve physical injury but may damage the machine.</p>

Safety Information, Continued..

## 1.1 Safety Precaution labels

 <b>CAUTION</b> MOVING PARTS INSIDE	<b>AVERTISSEMENT</b> LES PARTIES EN MOUVEMENT À L'INTERIEUR DE LA MACHINE	<b>PRECAUCIÓN</b>  PIEZAS MÓVILES ADENTRO
<ul style="list-style-type: none"> <li>- Do not operate with safety guard open.</li> <li>- Do not open safety guard until machine comes to a complete stop.</li> </ul>	<ul style="list-style-type: none"> <li>- Ne pas mettre en service si le dispositif de protection est ouvert.</li> <li>- Ne pas ouvrir le dispositif de protection avant l'immobilisation complète de la machine.</li> </ul>	<ul style="list-style-type: none"> <li>- No operar con el protector de seguridad abierto.</li> <li>- No abrir el protector de seguridad hasta que la máquina este completamente parada.</li> </ul>

Part No. 1785065



WARNING  
ADVERTENCIA  
AVERTISSEMENT

- This machine is not explosion proof rated.
- Review product label, Material safety Data Sheet, and HMIS rating of materials and exposures prior to mixing to determine potential hazards.
- Use in dry and well-ventilated environment where dust and flammable vapors are not present; risk of physical injury exists if used in hazardous environment.
- All containers must be properly sealed and void of leaks.

- Esta máquina no tiene la clasificación de prueba de explosión.
- Revise la etiqueta del producto, la hoja informativa de datos de seguridad, su clasificación HMIS antes de mezclar y exposiciones de materiales peligrosos para determinar los peligros potenciales.
- Use en un ambiente seco y bien ventilado donde polvo y vapores inflamables no estén presentes; Riesgo de daño físico existe si es utilizado en un ambiente peligrosos.
- Todos los contenedores deben estar bien sellados y sin fugas.

- Cette machine n'est pas classé antidéflagrant.
- Examen étiquette du produit, Fiche de données de sécurité, Et matériel HMIS cote et expositions, avant de faire le mélange pour déterminer les risques potentiels.
- Utilisation à sec et bien aéré environnement où la poussière et les vapeurs inflammables ne sont pas présents; risque de blessure physique existe si utilisé en environnement dangereux.
- Tous les conteneurs doivent être convenablement scellés pour éviter les fuites.

Part No. 1780899

WARNING  
ADVERTENCIA  
AVERTISSEMENT

- Machine must be properly grounded before use; improper grounding could cause electric shock and injury.
- Disconnect power cord before servicing, cleaning or removing any cover, and follow lockout/ tagout procedures in owner manual; failure to disconnect power could cause electric shock and injury.
- Review Owners Manual before installing or operating.

- La maquinaria debe ser apoyada correctamente en el suelo antes de usar, el no apoyarla puede causar choque eléctrico y daños.
- Desconecte la energía antes de dar mantenimiento, limpiar o quitar cualquier cubierta, y siga los procedimientos de bloqueo/etiquetado del manual, Fallar en desconectar puede causar choque eléctrico y daños.
- Revise el manual del usuario antes de instalar u operar.

- La machine doit être correctement mise à la terre avant de les utiliser mise à la terre incorrecte peut provoquer un choc électrique et de blessure.
- Debranchez le cordon d'alimentation avant de procéder à l'entretien, le nettoyage ou le retrait des capots: suivez la procédure d'isolation/consignation prévues dans le manuel de l'opérateur; E'chec de débrancher la source d'alimentation peut provoquer shock and électrique blessures.
- Re'examiner le fonctionnement manuel avant l'installation.

Part No. 1781570

Safety Information, Continued..

Safety Information, Continued..

## 1.2 Safety Precaution Summary

### **WARNING!**

 DO NOT attempt to replace any damaged electrical wire or components. Improper replacement could result in electric shock and serious injury. Only a qualified service representative should attempt to repair or replace any damaged electrical components.

 Review this owner's manuals before installing or operating.

 The machine must be properly grounded prior to use. In case of electrical short circuit grounding reduces the risk of electric shock by providing an escape wire for the electric current.

 The machine's power cord has a grounding wire with an appropriate grounding plug. This plug must be inserted into an electrical outlet that is properly installed and grounded according to all local codes and ordinances.

 If you must repair or replace the power cord or plug, **DO NOT** connect the grounding wire to either flat-blade terminal. The wire with insulating having an outer surface that is green (with or without yellow stripes) is the grounding wire.

 Check with a qualified electrician if you don't completely understand these grounding instructions, or if you are not sure whether the machine is properly grounded. **DO NOT** Modify the plug provided; if it won't fit in the outlet, have a proper outlet installed by a qualified electrician.

 Disconnect the power cord before servicing, cleaning, or removing and covers.

 Follow the lockout/tagout procedures of your company.

 Do Not use the door until the machine comes to a complete stop.

 To avoid electric shock, don't get the timer, control panel, or wiring wet.

 This machine is not explosion proof rated.

 All containers must be properly sealed and void of leaks. Review product label, Material Safety Data Sheet, and HMIS rating of material prior to mixing to determine potential hazards.

 Do not use solvent-based cleaners or thinners

 Use in a dry and well-ventilated environment where dust and flammable vapor are not present.

 Review product label, Material Safety Data Sheet, and HMIS rating of material prior to mixing to determine potential hazards.

 Do not use solvent-based cleaners or thinners

 Use in a dry and well-ventilated environment where dust and flammable vapor are not present.

### **CAUTION!**

 Keep the work area free of clutter and electrical cords.

 Avoid extension cords. To minimize the risk of improper electrical grounding, extension cords are not recommended. If an extension cord is unavoidable, consult a qualified electrician to determine what type of extension cord will satisfy the grounding, current capacity, and other requirements of the particular situation.

 Use the proper power source. Refer to the machine data plate on the right side panel or the section 2.1, Specifications, in this manual.

 Keep customers away from the work area. This machine should be used only by properly trained individuals.

 Clamp the can carefully to ensure that it is held securely during the mixing cycle.

**Product safety labels should be inspected and cleaned periodically to maintain good legibility. Replace any labels that are no longer legible.**

 **WARNING: This product may expose you to chemicals including DEHP, which is known to the State of California to cause cancer. For more information, go to [www.P65Warnings.ca.gov](http://www.P65Warnings.ca.gov)**

## 2. Introduction

### 2.1 Application

Congratulations on your purchase of the Classic Shaker. This machine is designed to accommodate standard gallon, quart and pint plastic or metal cans weighing up to 18 lb. (8.2 kg).

This mixer **MUST BE USED** in conjunction with either a countertop or pedestal base, sold separately.

Understand your machine's features and proper operation to take full advantage of its capabilities.

Read this entire manual completely before operating the machine. Practice installing and removing a container before mixing for the first time.

Keep this manual for future reference.

**Always follow all safety instructions!**

### 2.2 Specifications

#### Unit Size

- **1400-00, 1400-PB, 1400-OH, 1400-DD:**  
**W** 41.63 in. (105.74 cm) **D** 29.63 in. (75.26 cm) **H** 31.50 in. (80.01 cm)
- **1410-00, 1410-PB, 1400-OH, 1400-DD:**  
**W** 27.88 in. (70.81 cm) **D** 29.63 in. (75.26 cm) **H** 31.5 in. (80.01 cm)

#### Shipping Weight:

- **1400-00, 1400-PB, 1400-OH, 1400-DD:** 191 lb. (86.6 kg)
- **1410-00, 1410-PB, 1400-OH, 1400-DD:** 160 lb. (72.6 kg)

**Electric Service:** 120 V 60 Hz or 220 V 50 Hz (E5 only)

**Capacity:** 18 lb. (8.2 kg)

**Sizes Mixed:** 1 gal., 1qt., 1 pt.

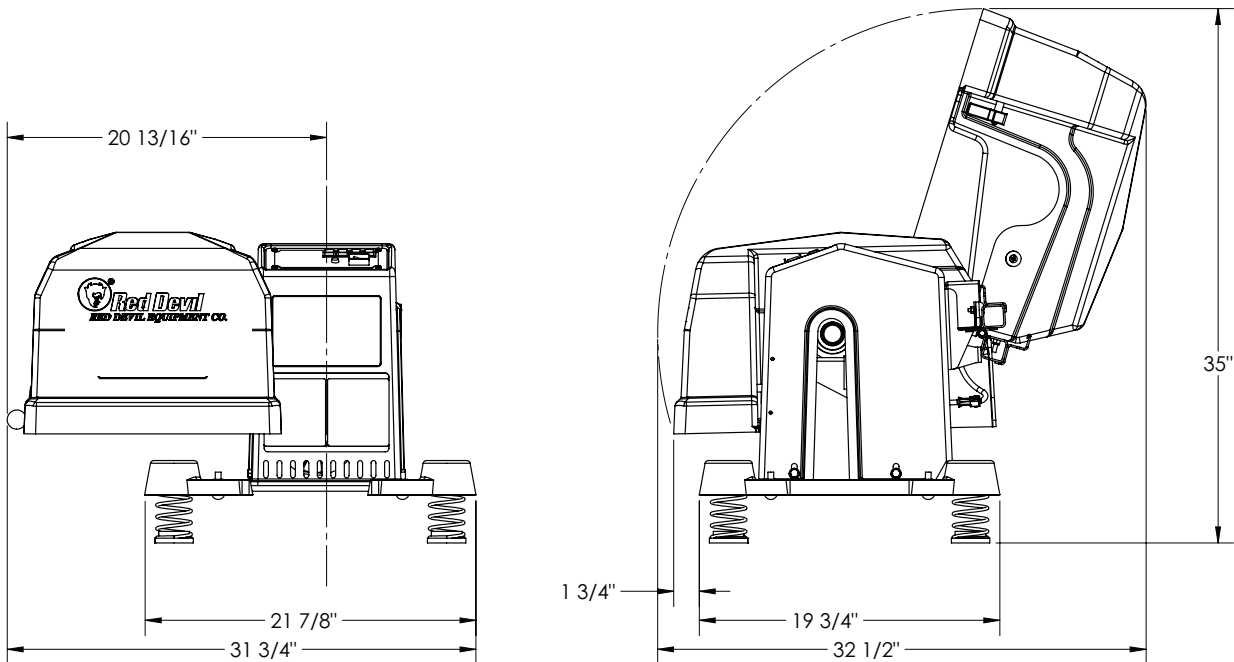

### Single Gallon

**1410-PB** 120V/60 Hz 6 Min Pushbutton Timer

**1410-00** 120V/60Hz 15 Min Mech Timer

**1410-OH** 120V/60Hz 1 Hour Mech Timer

**1410-DD** 120V/60Hz 2 Button Digital Display

Mounted on Countertop or Pedestal Base.

Introduction, Continued..

... Introduction, Continued

## 2.2 Specifications

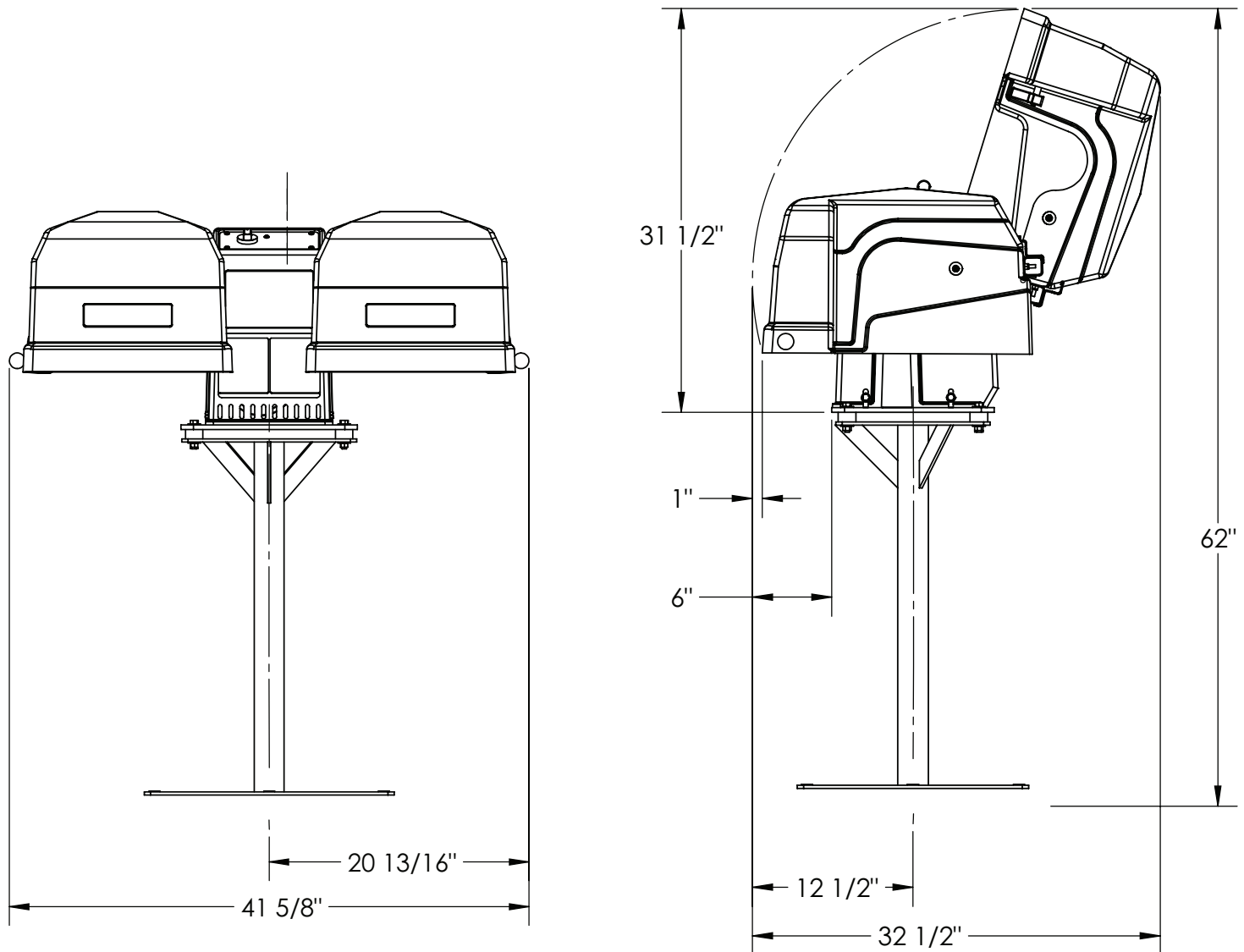

### Twin Gallon

- 1400-PB** 120V/60 Hz 6 Min Pushbutton Timer
- 1400-00** 120V/60Hz 15 Min Mech Timer
- 1400-0H** 120V/50Hz 1 Hour Mech Timer
- 1400-DD** 120V/60Hz 2 Button Digital Display

Mounted on Countertop or Pedestal Base.

... Introduction, Continued

## 2.3 Control Panel Pushbutton Timer

- **Timer Selection (A-D):** Select the desired mix time. The machine starts to mix when the time is selected.
- **Mixing Indicator (E):** This light is on during a mix cycle.
- **On/Off Switch (F):** Turn on before starting a mix cycle. Turn off when the machine is not in use.

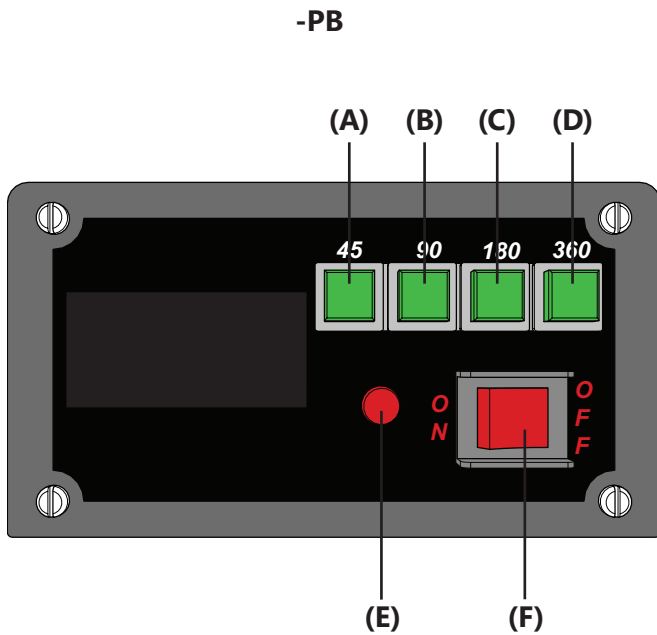

## 2.3 Control Panel Mechanical Timer

Turn the dial to the appropriate mix time. The machine starts to mix when the time is selected.

### -00 (15 Minute Timer)

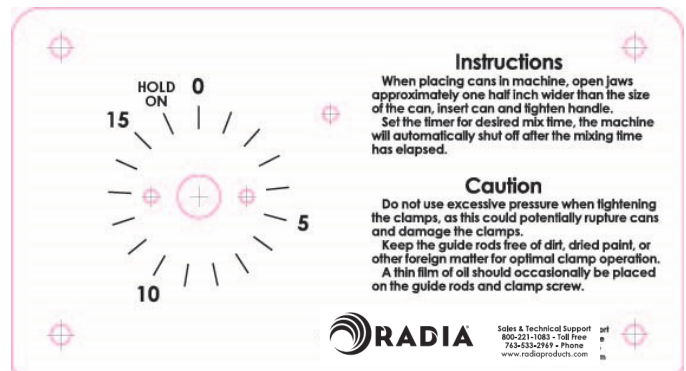

### -0H (1 Hour Timer)

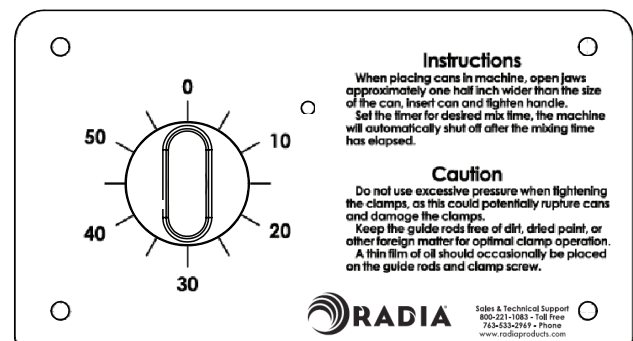

... Introduction, Continued

## 2.4 Control Panel Digital Display

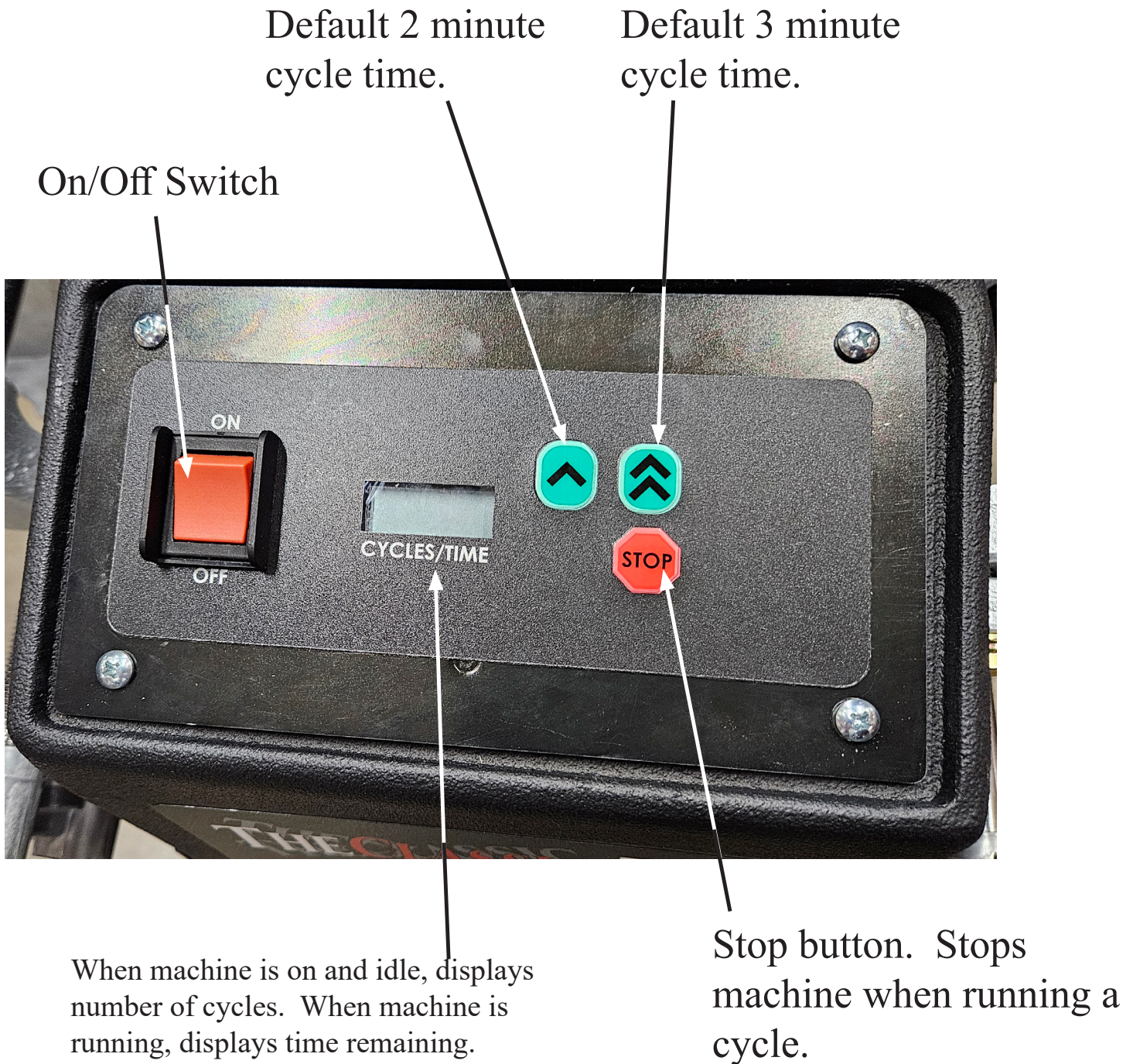



... Introduction, Continued

## 2.4 Control Panel Digital Display continued

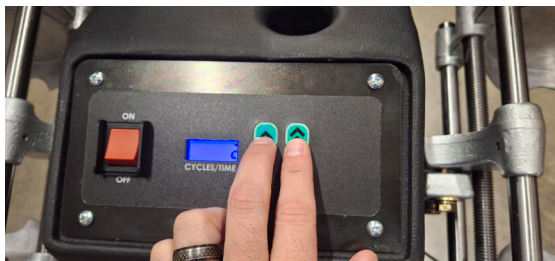

Changing the shake time on your 1400 or 1410 DD model paint shaker.

1. 1. Ensure the hoods are open.  
Turn the Power Switch to On position and allow machine to fully boot. Display will show the cycle count.

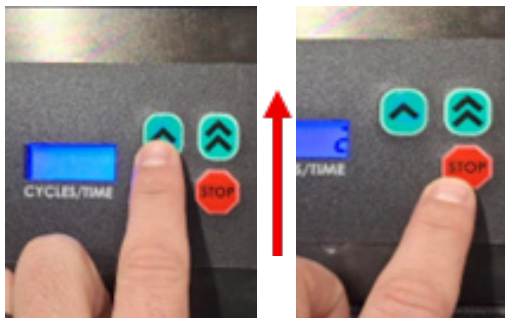

2. Next, press and hold both the  and the  buttons until the number on the display begins to flash.



3. Press the timer button you wish to change, either the  or the  button. If you wish to increase the time, continue to press the same timer button. To decrease the time, press the  button.

4. Once the desired time is reached, wait for the number on the display to stop flashing. Once it has stopped flashing, the time is saved.

**NOTE:** If you wish to change both times, you will have to start the process over and select the timer button previously not selected in step 3.

## 3. Assemble and Test

### 3.1 Prepare for Use

**IMPORTANT:** Before attempting to operate the machine:

1. Remove all packing material.
2. Assemble the base.

### 3.2 Assemble the Countertop Base

1. Attach both base castings **(A)** to the mixer, using the four carriage bolts **(B)**, washers **(C)**, and nuts **(D)** provided.
2. Install a rubber foot **(E)** into each end of the springs **(F)**.
3. Lift one side of the mixer. Insert a spring and foot assembly into the depression in the bottom of each corner of the base **(G)**.
4. Lift the other side of the mixer, and repeat the third step.

**NOTE:** Be sure that the machine and base are placed on a flat, stable countertop surface.

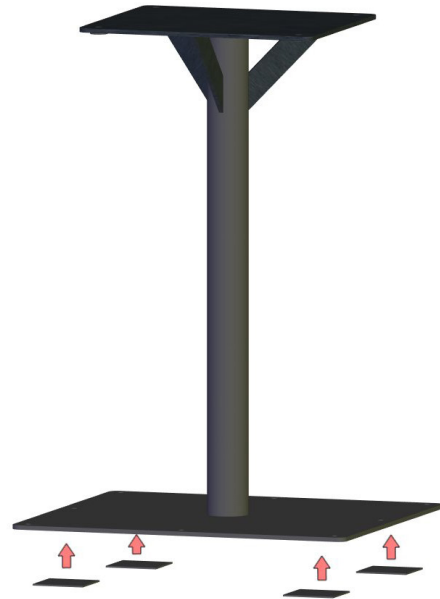
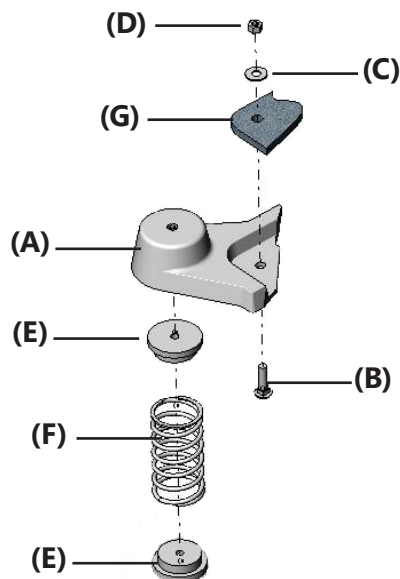

### 3.3 Assemble the Pedestal Base (See Section 8.11)

1. Wipe bottom of pedestal base with alcohol, acetone, or equivalent.
2. Sweep floor and wipe with alcohol, acetone, or equivalent.
3. Adhere VHB pads (4) to bottom of pedestal base as shown above.
4. Place pedestal base on clean floor.

**NOTE:** Moving Pedestal Base: If it becomes necessary to move the machine to a different location, release the bond between the floor and pedestal base by inserting a wall scraper between them. Contact Red Devil Equipment Co. / Radia for replacement VHB pads.

## Assembly and Test, Continued..

5. Set the mixer on the upper plate of the base, on top of the rubber bumpers (**F**)
6. Secure the mixer to the base using the four rubber bumpers, bolts (**G**), washers (**H**), and nuts (**I**) provided.

**NOTE:** DO NOT overtighten the nuts.

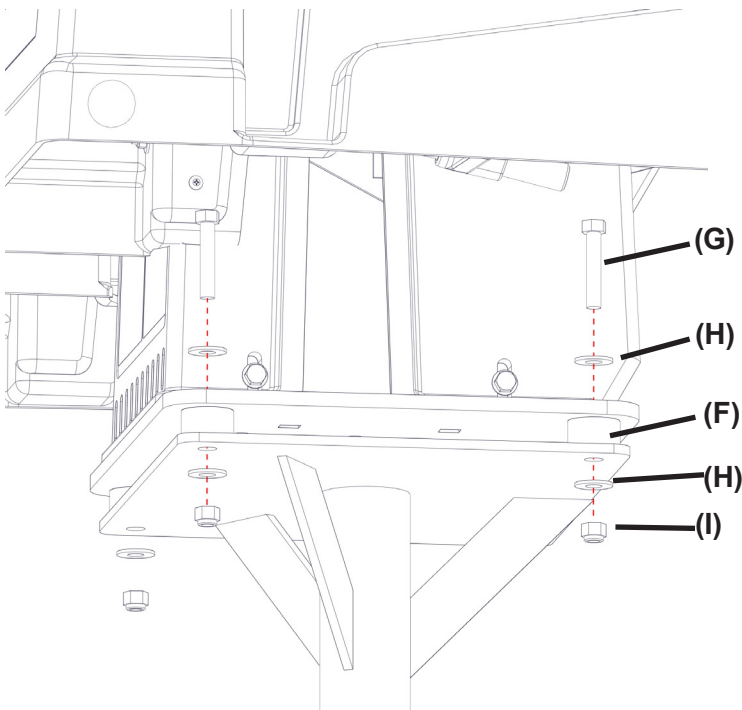

7. Adjust the fasteners.
  - a. Tighten all four bolts to just snug
  - b. Turn all four bolts 1 1/2 more turns.
  - c. Adjust the bolts as required to ensure the gap between the mounting base and the unit is 1/2 inch at all four bolts. This compresses the isolators equally.

**Notice:** Failure to follow the directions laid out in this Section will cause the warranty to be void. Per Section 10: "This warranty does not cover, and Radia shall not be liable for, any malfunction, damage, or wear caused by faulty installation"

## 3.4 Valve Cap Removal

1. Remove the Valve Cap prior to operation.



## 3.5 Connect to Power

1. Follow the electrical instructions described in sections 1.2 & 2.2

The machine power cord has a grounding wire with an appropriate grounding plug. This plug must be inserted into an electrical outlet that is properly installed and grounded according to all local codes and ordinances.

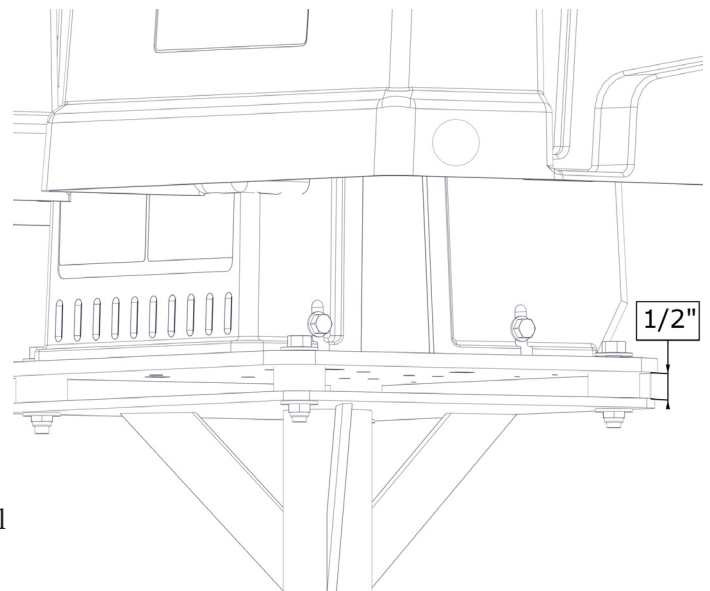

## 4. Operation

### 4.1 Install a Pail and Mix

**⚠ WARNING!** Avoid serious personal injury. Do not mix flammable or combustible materials in this mixer.

1. Turn the handle counter-clockwise to open the clamping jaws about 1/2" wider than the length of the container.
  2. Insert the can and turn the handle clockwise to secure
- ⚠ Notice:** Avoid damage to the machine. Do not operate the machine without a can installed.

the can for mixing. Before turning on the mixer, always be sure that the container is held tightly-but don't use excessive pressure that could damage the can or clamping assembly.

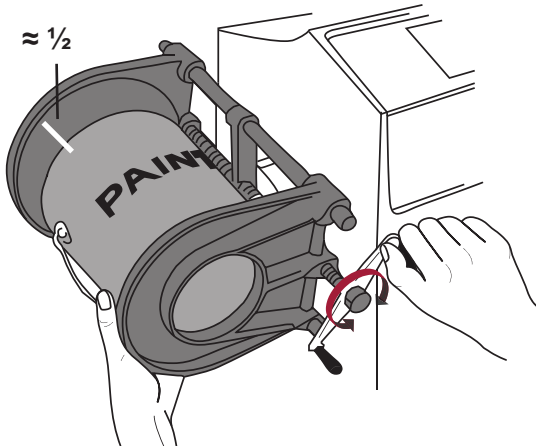

3. If mixing with only one clamp on a Model 1400, install an empty can (or a piece of 2" x 4" board) in the other clamp.
4. If your model has a pushbutton timer, close the clamp guard, then:
  - a. Set the power switch to ON.
  - b. Select desired mixing time by pressing the appropriate button to initiate the mix cycle.
5. If your model has a mechanical timer, turn the dial to the appropriate time increment. The machine will start automatically once the dial is moved off of zero.

## 5. Care & Maintenance

**⚠ WARNING!** Avoid serious personal injury. Always unplug the power cord before performing maintenance tasks.

### 5.1 Cleaning

**⚠ WARNING!** Avoid serious personal injury! DO NOT use solvent-based cleaners or thinners, or other combustible cleaners.

- Remove water-based/glycol colorants or base paints spilled on machine surfaces using lukewarm water and mild detergent.
- Do not use abrasives to clean machine surfaces. Doing so may damage the appearance of the machine.
- Keep the machine clean for reliable operation.

### 5.2 Maintenance

Lubrication:

- Measure the oil level periodically. Be sure the oil level is between the two marks on the dip stick. Use a full synthetic SAE 10W 30 motor oil.
- Avoid using too much oil as it could cause seepage around the main shaft. The capacity of the transmission is 11 oz.
- Keep the guide rods free of dirt, dried paint, and other foreign matter.
- Remove any small nicks with a fine file.
- Whenever the guide rods feel dry, wipe a little oil over them with a rag.
- Occasionally apply a thin film of oil to the clamp screws.

## 6. Troubleshooting

PROBLEM	CAUSE	REMEDY
Machine won't operate	Not connected to power source	Connect to power source
	Loose or broken wire connection	Have a qualified electrician replace or repair the wire connection
	Machine door does not make contact with limit switch	Readjust switch to make contact with limit switch tab when door is closed
	Limit switch actuator does not make contact with limit switch	Readjust switch to make contact with limit switch screw when the cover is
	Mixer guard is not closed completely	Remove any obstruction and close the guard properly
	Motor Thermal Protector Activated	Allow to cool, then restart
	Faulty Control Panel	Contact Radia Customer Care
	Faulty Motor	Contact Radia Customer Care
Can won't fit properly into clamping plates	Can damaged	Fix or replace Can
Clamp does not hold cans securely	Clamp threads are worn	Replace the clamp assembly
Machine doesn't shut off at end of mixing cycle	Faulty timer/controller	Contact Radia Customer Care
Machine doesn't shut off when guards are lifted	Faulty limit switch	Contact Radia Customer Care
Mixer Walking	Mixer is not on a Radia Equipment approved base	Contact Radia Customer Care
	Floor is not smooth	Anchor base to Floor, see section 3.5
Excessive Noise	Loose nuts on the mounting base	Tighten the nuts
	Guards are loose	Tighten the nuts
	Clamp plate loose	Contact Radia Customer Care
	Worn transmission bearings	Contact Radia Customer Care
Squeaking noise at the back of the machine	Hinge parts on the clap guards are rubbing against each other	Use spray lubricant on the hinge
Machine starts or runs slowly	Loose drive belt	Tighten or replace the drive belt

## 7. Wiring Diagrams

### 7.1 14XX - PB Models

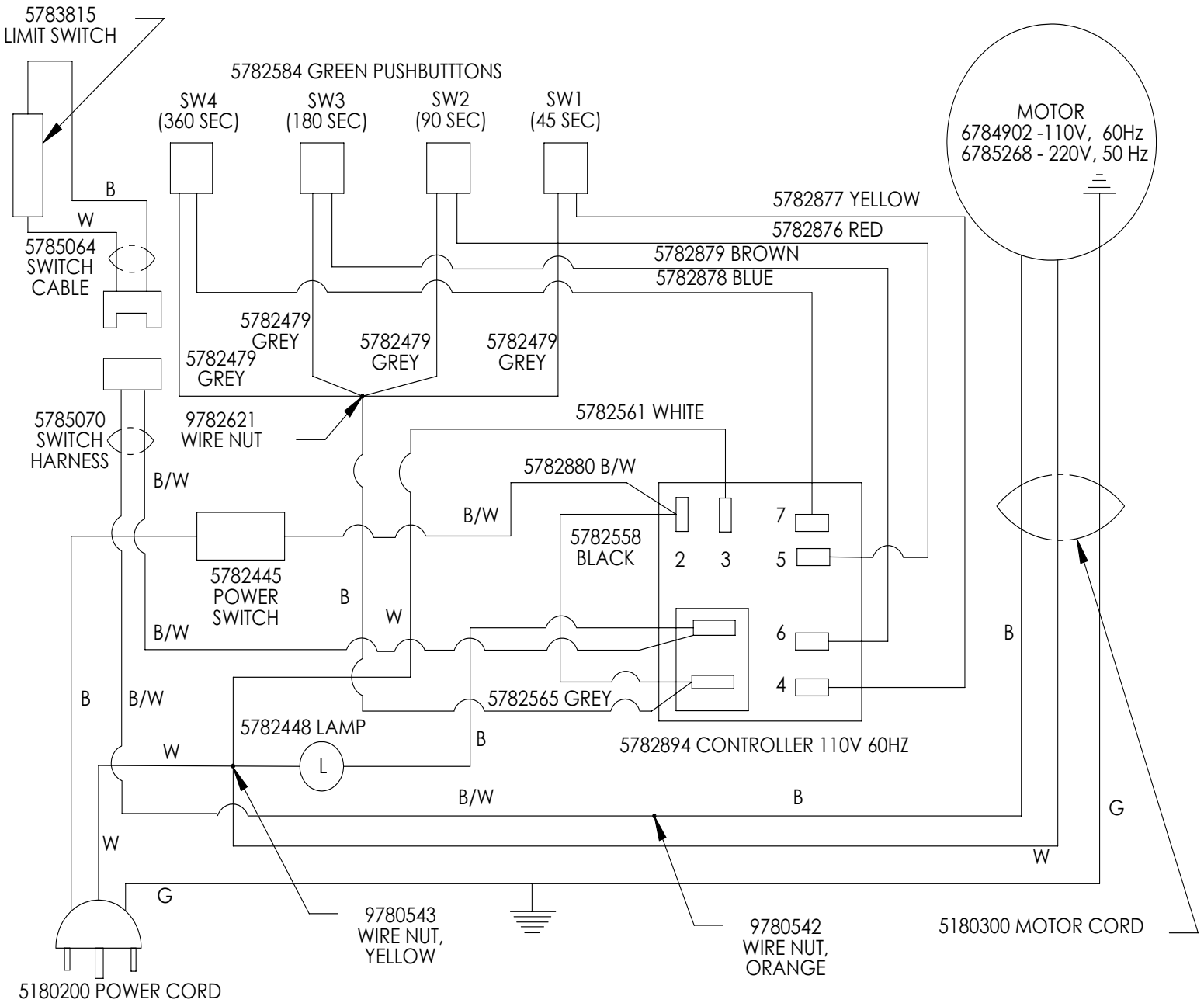

...Wiring Diagrams, Continued

## 7.2 14XX - 00 and 0H Models

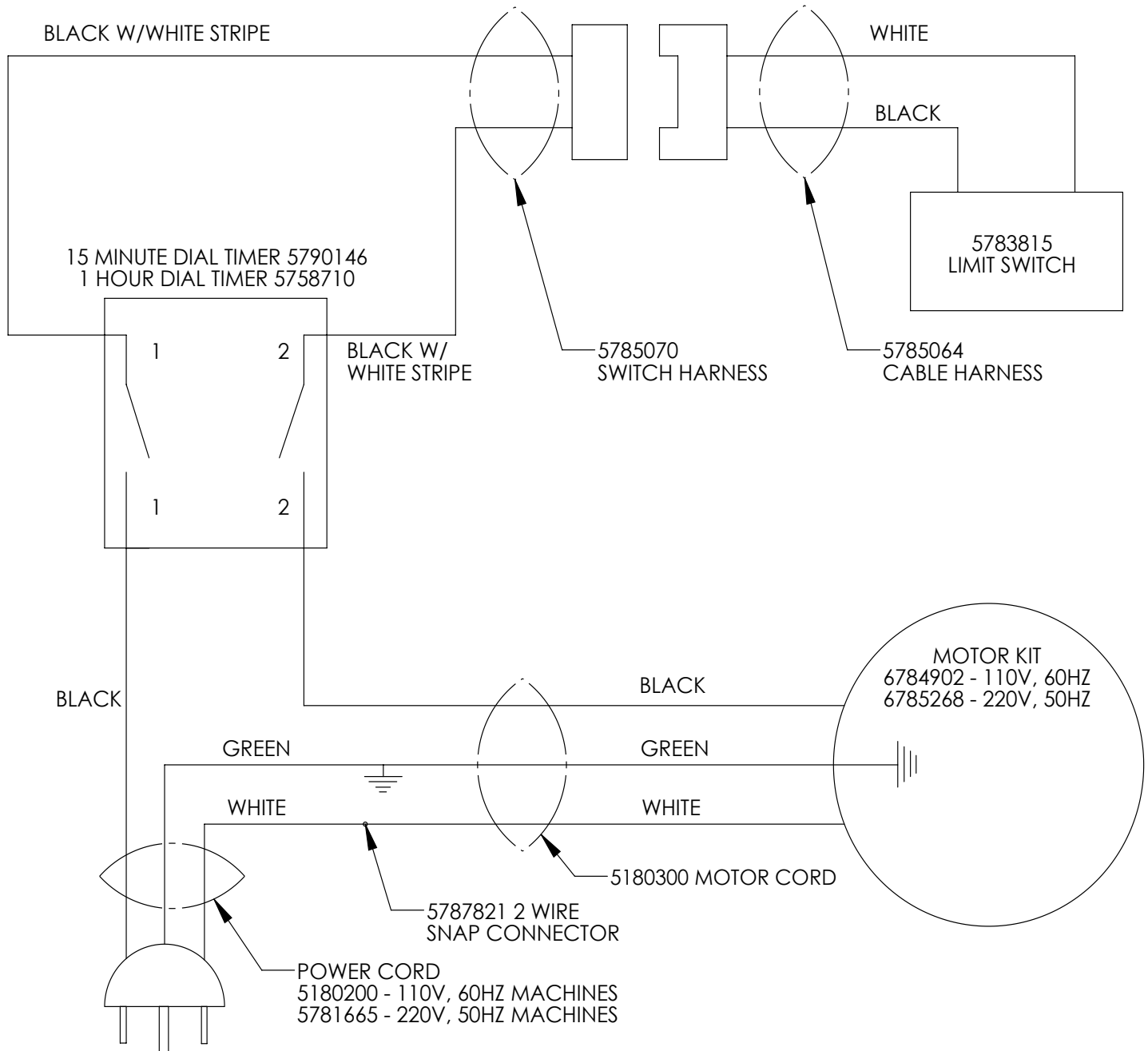

Wiring Diagrams, Continued..

...Wiring Diagrams, Continued

## 7. 14XX-DD

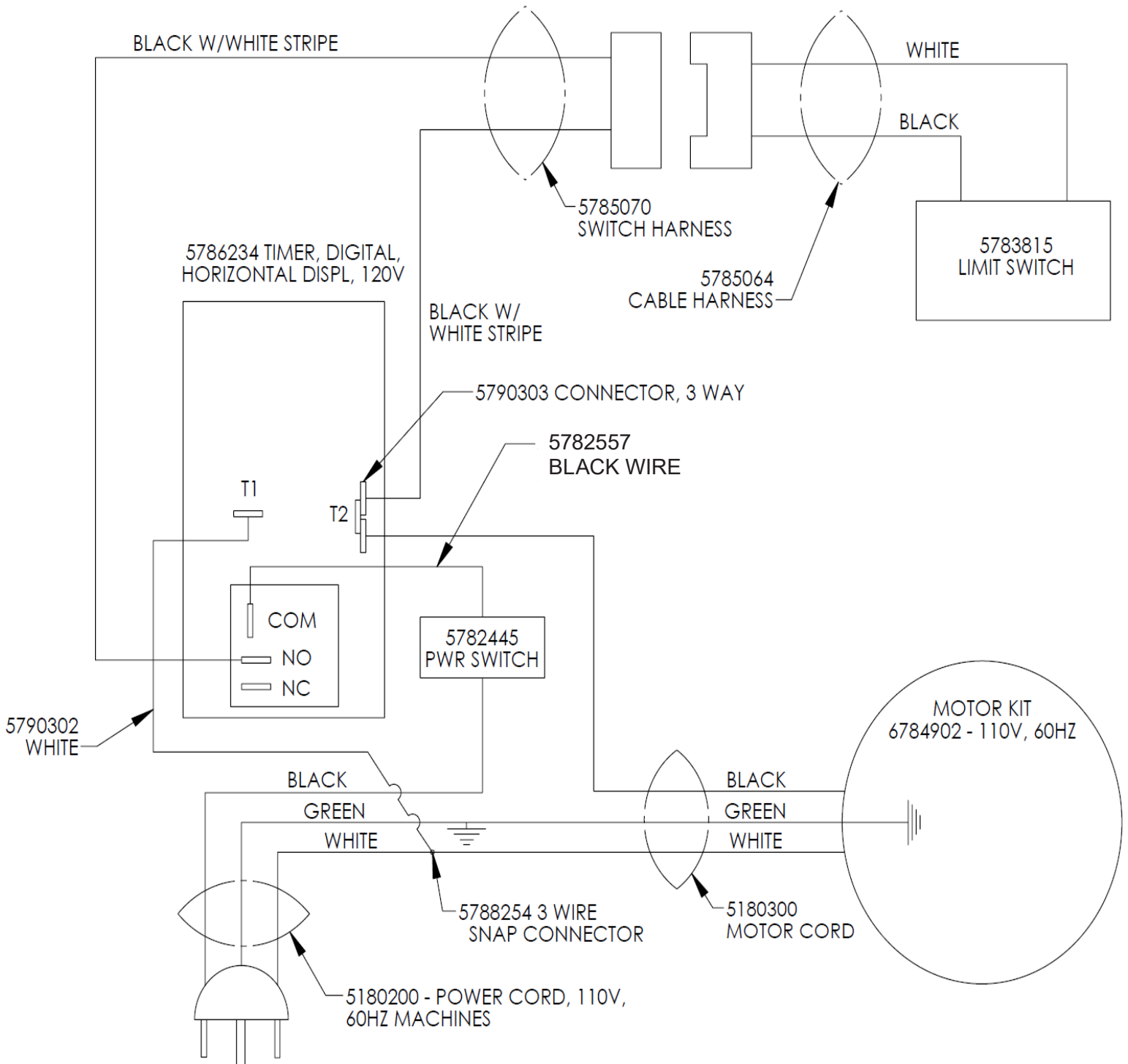

...Wiring Diagrams, Continued

## 7.4 Internal Motor Wiring for 120V/60 Hz and 220V / 50 Hz Models

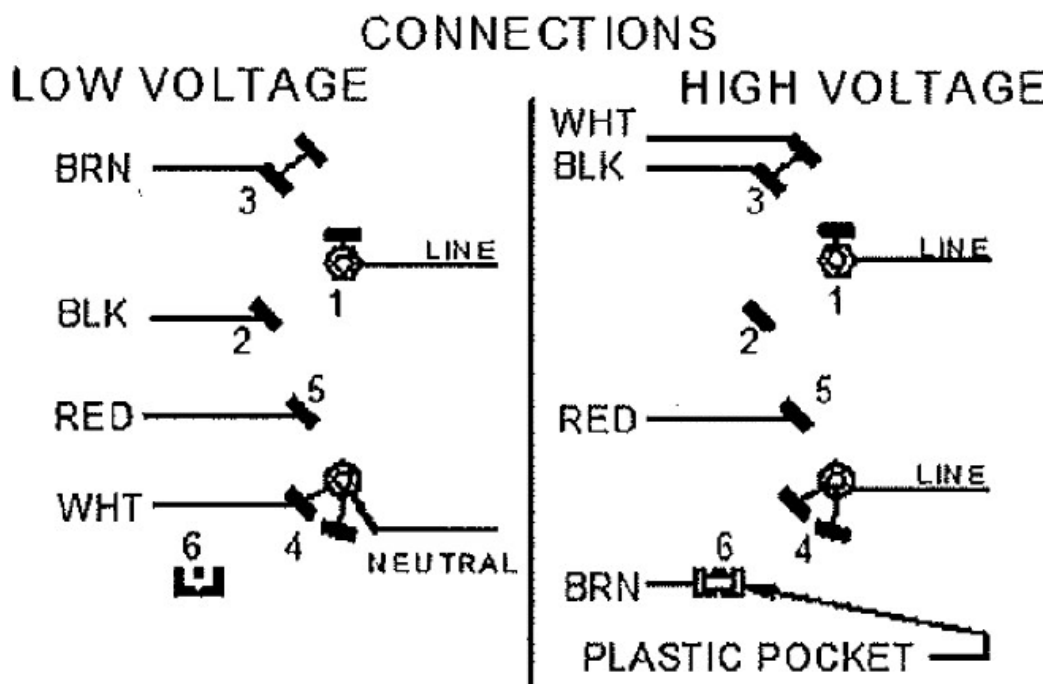

Motor Voltage Connections for 120 and 220 V

	Lead	120V	220V
Line In-----	Brown	3	6
	White	4	3
	Red	5	5
Ungrounded Line	Black	2	3

## 8. Exploded Views

### 8.1 Drive system

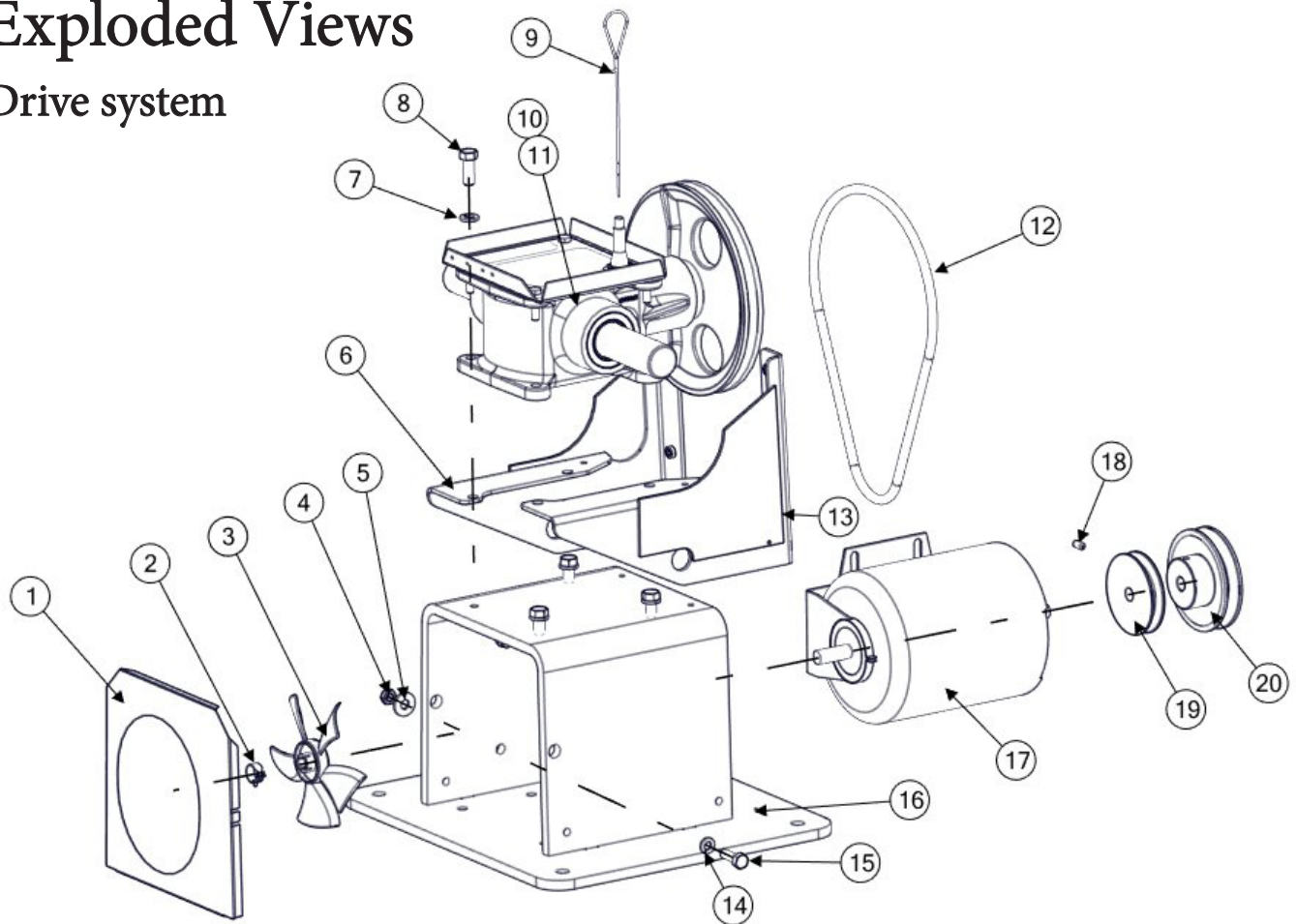

ID	PART #	DESCRIPTION	ID	PART #	DESCRIPTION
1	9621700	BAFFLE, 1400/10	12	9592800	BELT,ROUND-POLYURTHANE
2	9621600	RING, COMPRESSION-FAN	13	9785062	HINGE BRACKET, TRANS, RH
3	9786120	FAN, BLAD, CCW, 5.0 DIA	14	9760521	WASHER, LOCK SPLIT 5/16
4	9781493	NUT, NYLOCK JAM 5/16-18	15	9561700	SCREW, HEX HD CAP 5/16-18 X 1
5	9100023	WASHER, FLAT 5/16 USS	16	8621200	BASE WELDT, PAINTED
6	9785061	HINGE BRACKET TRANS LH	17	MOTOR	SEE KITS
7	9780402	WASHER, LOCK SPLIT 3/8	18	9159800	SCREW, SET CUP 1/4-20 X 1/2
8	9788040	SCREW HEX HD 3/8-16 X 1	19	9619000	PULLEY, MOTOR 60 HZ MTR
9	9622700	DIPSTICK	20	9786047	PULLEY, MOTOR 50 HZ MTR
10	6785273	KIT, TRANSMISSION - 1400	KIT	6784902	KIT, MTR REPL 110/60HZ (includes 17, 18, 19, 2, 3, and harness)
11	6785275	KIT, TRANSMISSION - 1410	KIT	6785268	KIT, MTR REPL 220/50HZ (includes 17, 18, 20, 2, 3, and harness)

**PART NUMBERS LISTED MAY ONLY BE AVAILABLE IN KIT FORM OR AS AN ASSEMBLY**

Exploded Views, Continued..

...Exploded Views, Continued

## 8.2 Transmission Assembly

1400 Transmission Kit: 6785273

1410 Transmission Kit: 6785275

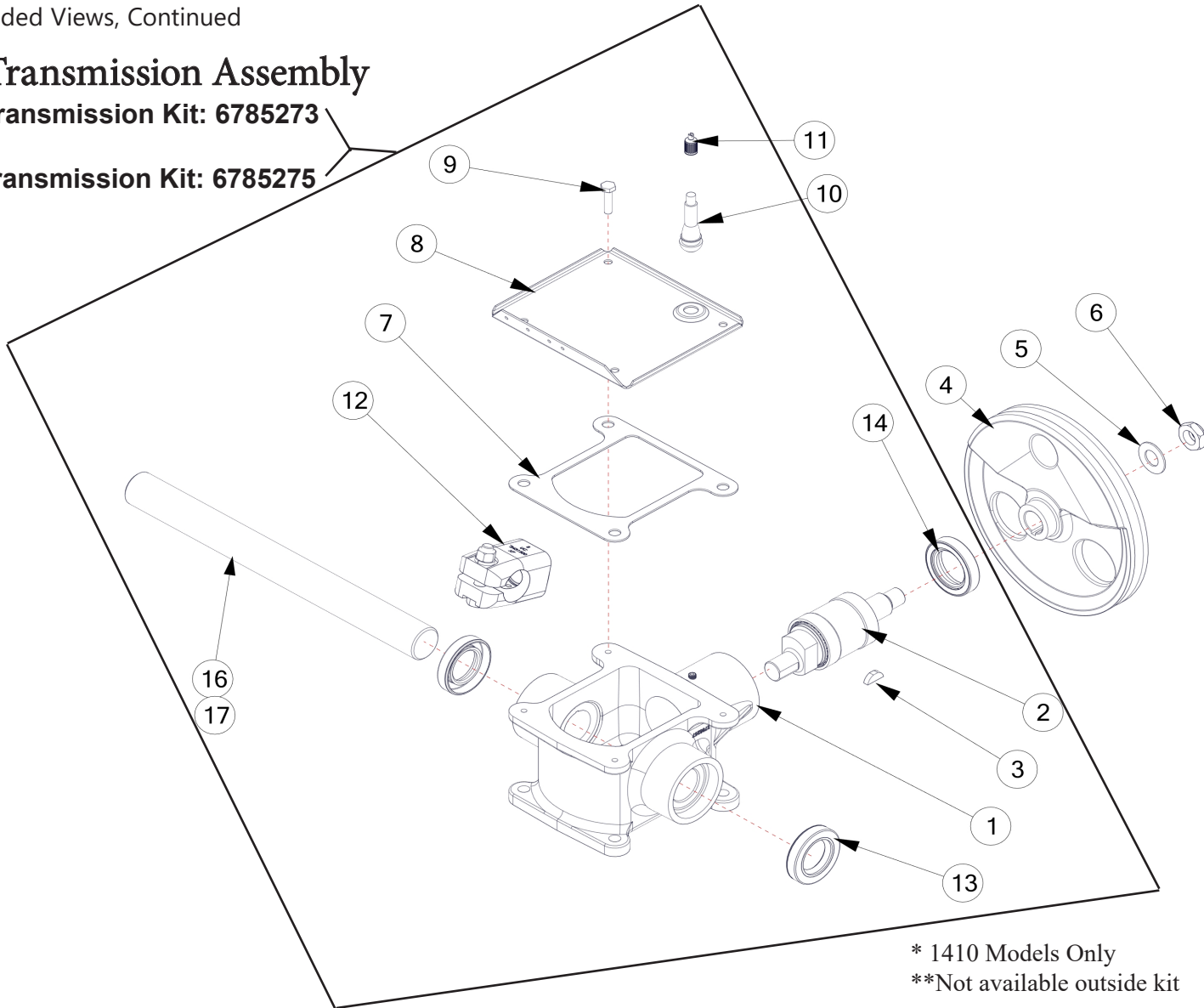

\* 1410 Models Only

\*\*Not available outside kit

ID	PART #	DESCRIPTION	ID	PART #	DESCRIPTION
1**	9786258	BEARING HOUSING	10	9622800	VALVE STEM
2**	6808900	ASSY, CRANKSHAFT	11	9622600	CAP, SCHRADER VALVE
3	9124700	KEY, WOODRUFF, NO. 606	12**	6803200	BLOCK, UNIVERSAL ASSY
4	9694000	PULLEY, COUNTERWEIGHT	13	9157400	SEAL, OIL, AGITATOR SHAFT
5	9690300	WASHER, COPPER, FLAT	14	9359200	SEAL, OIL, CRANKSHAFT
6	9694100	NUT, NYLOCK, THIN, 5/8-18	16**	9341700	SHAFT, AGITATOR, DUAL
7	9430300	GASKET BEARING HOUSING	17**	9339600	SHAFT, AGITATOR, SINGLE *
8	9668300	COVER, BEARING HOUSING	KIT	6785273	1400 TRANSMISSION ASSY
9	9788039	SCREW, HEX 1_4 X 1 GR8			

**PART NUMBERS LISTED MAY ONLY BE AVAILABLE IN KIT FORM OR AS AN ASSEMBLY**

Exploded Views, Continued..

...Exploded Views, Continued

## 8.2 Clamp Assembly, Left

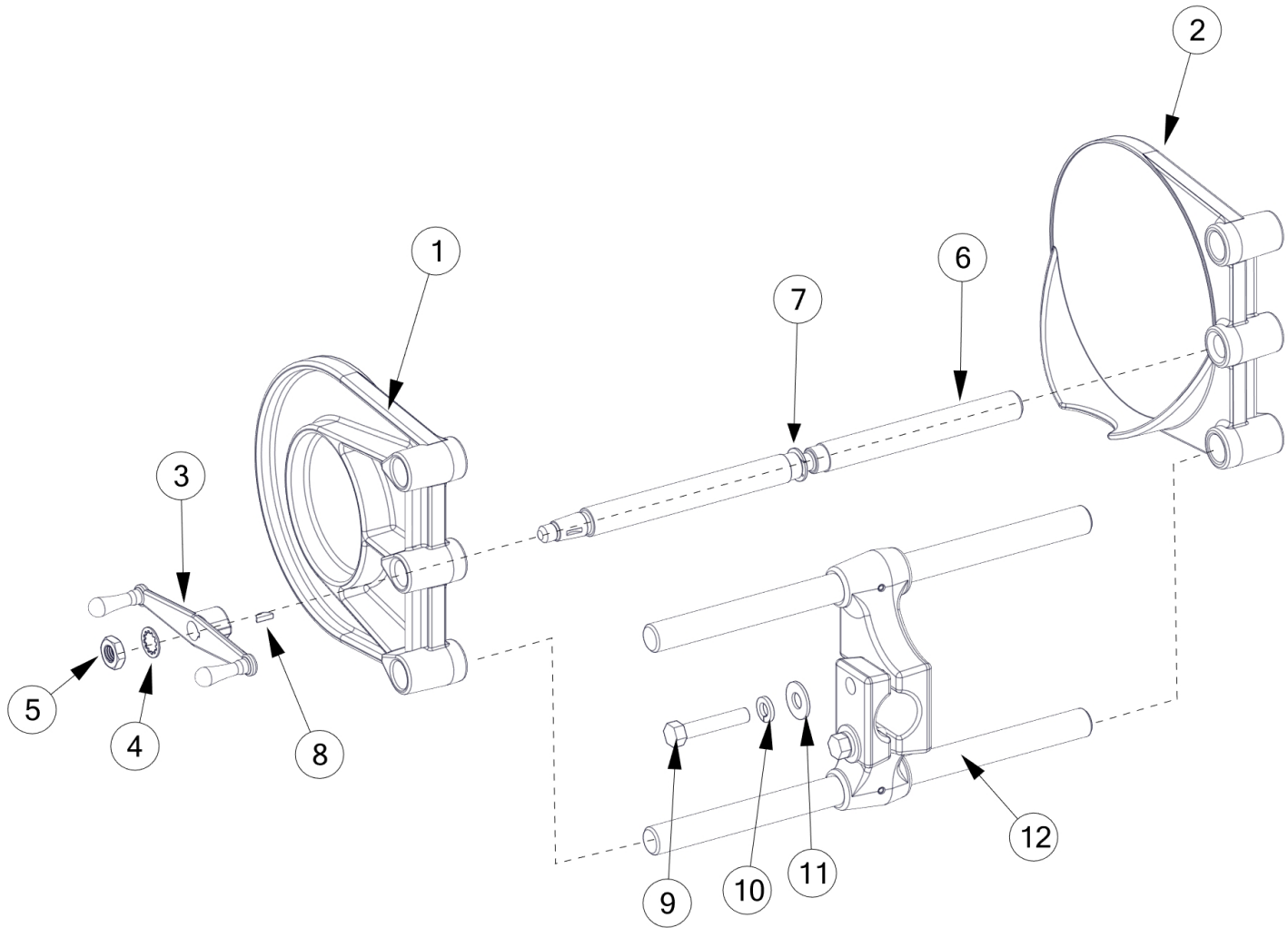

\* UNAVAILABLE OUTSIDE KIT

ID	PART #	DESCRIPTION	ID	PART #	DESCRIPTION
1	9784822	CLAMP JAW, LEFT FRONT	8	9140200	KEY, WOODRUFF NO 404
2	9784821	CLAMP JAW, LEFT REAR	9	9690800	SCREW, HEX 3/8-16 X 2.00
3	9188100	HANDLE, CLAMP 5400	10	9780402	SPLIT LOCK WASHER 3/8
4	9143900	WASHER, INTERNAL TOOTH LOCK - 7/16	11	9161100	WASHER, FLAT 3/8 USS
5	9138100	NUT, HEX JAM - 7/16-20	12*	6784823	ASSY, GUIDE ROD, HD
6*	6782224	CLAMP SCREW - 14XX	KIT	6785100	14XX CLAMP ASSEMBLY - LEFT SIDE
7	9782216	THRUST WASHER			

**PART NUMBERS LISTED MAY ONLY BE AVAILABLE IN KIT FORM OR AS AN ASSEMBLY**

Exploded Views, Continued..

...Exploded Views, Continued

## 8.4 Clamp Assembly Right

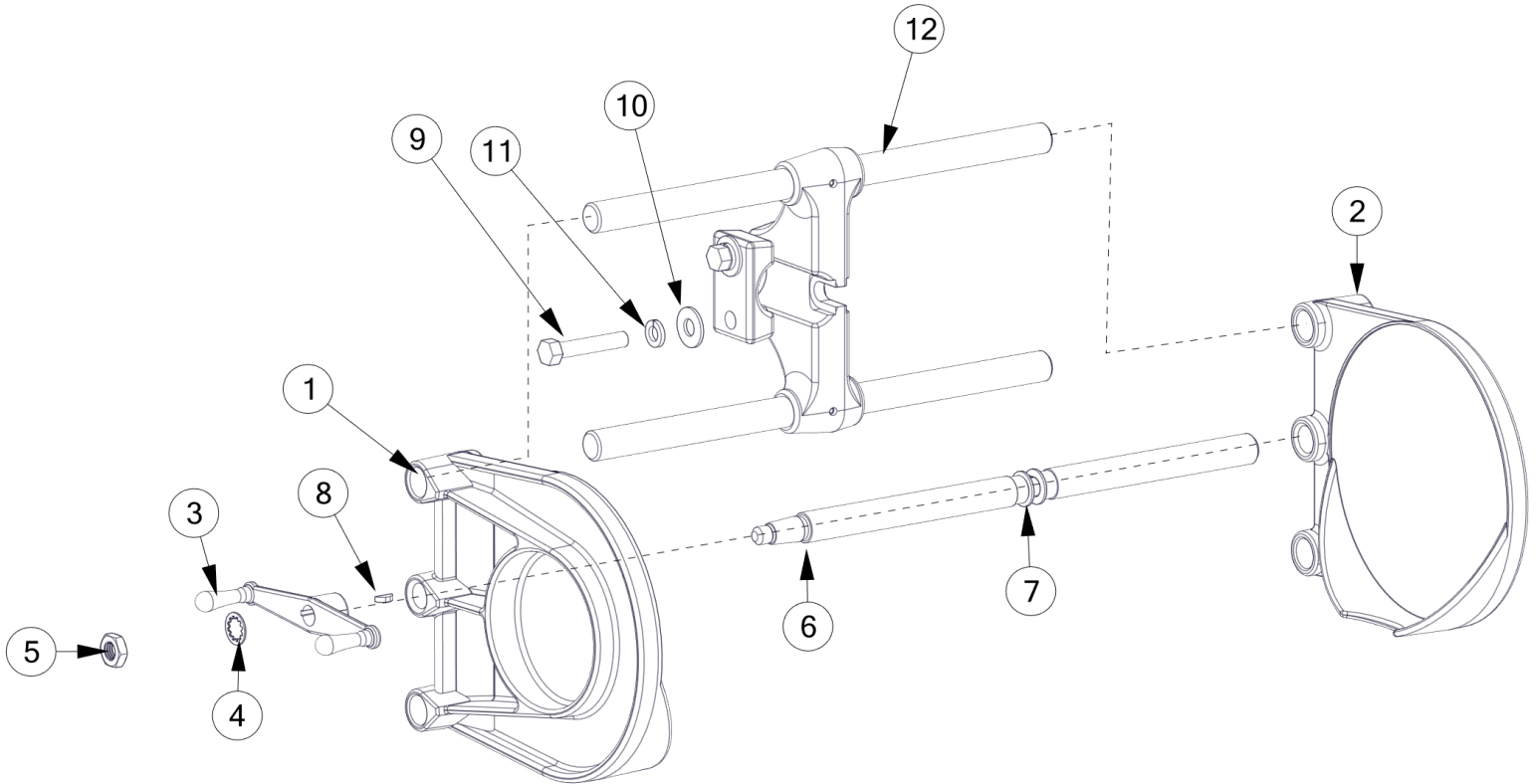

\* UNAVAILABLE OUTSIDE KIT

ID	PART #	DESCRIPTION	ID	PART #	DESCRIPTION
1	9784820	CLAMP JAW, RIGHT FRONT	8	9140200	KEY, WOODRUFF NO 404
2	9784819	CLAMP JAW, RIGHT REAR	9	9690800	SCREW, HEX 3/8-16 X 2.00
3	9188100	HANDLE, CLAMP 5400	10	9780402	SPLIT LOCK WASHER 3/8
4	9143900	WASHER, INTERNAL TOOTH LOCK - 7/16	11	9161100	WASHER, FLAT 3/8 USS
5	9138100	NUT, HEX JAM - 7/16-20	12*	6784823	ASSY, GUIDE ROD, HD
6*	6782224	CLAMP SCREW - 14XX	KIT	6785101	14XX CLAMP ASSEMBLY - RIGHT SIDE
7	9782216	THRUST WASHER			

**PART NUMBERS LISTED MAY ONLY BE AVAILABLE IN KIT FORM OR AS AN ASSEMBLY**

Exploded Views, Continued..

...Exploded Views, Continued

## 8.5 Enclosure Assembly

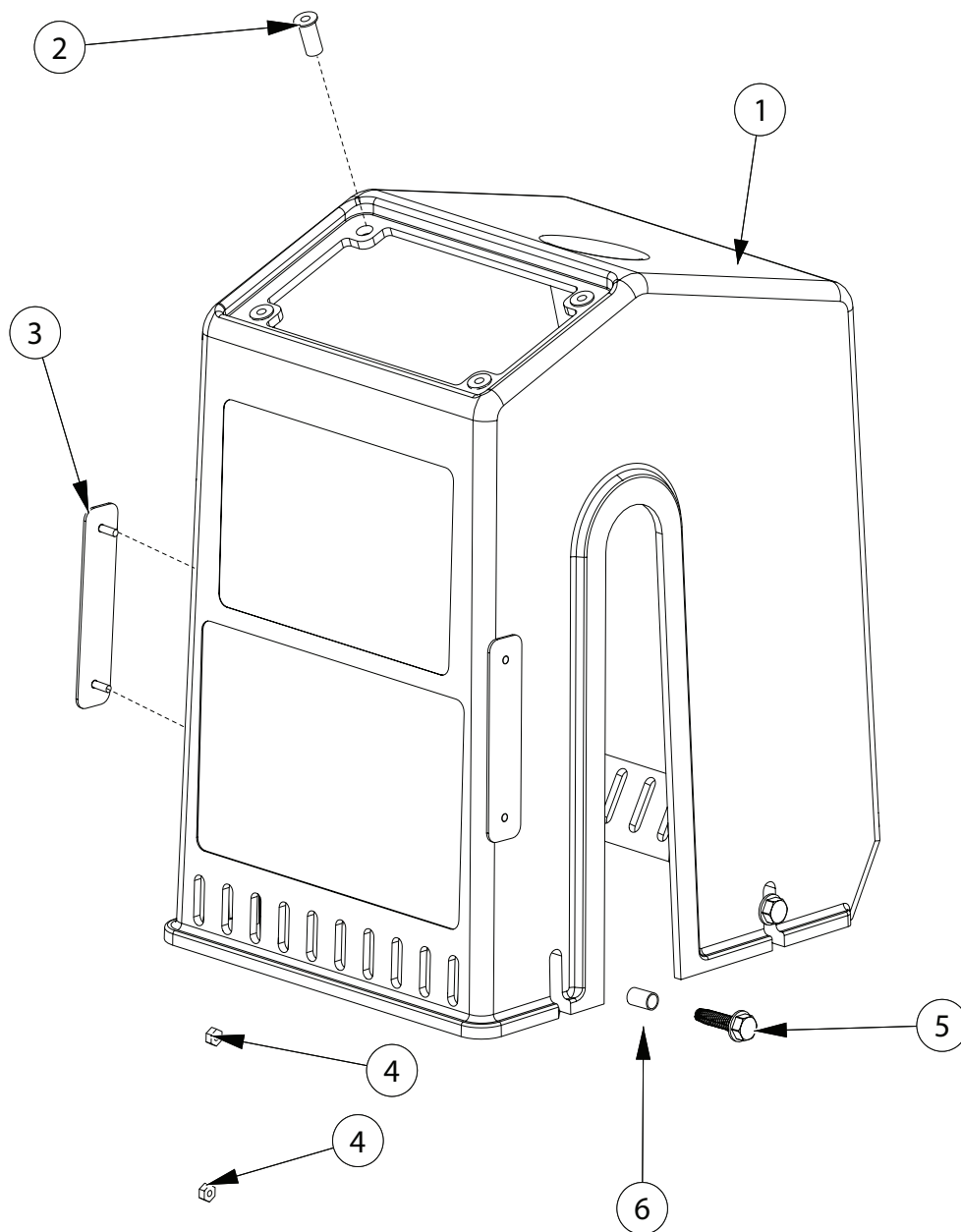

ID	PART #	DESCRIPTION	ID	PART #	DESCRIPTION
1	9785040	ENCLOSURE, CLAMP COVER	4	9781840	NUT, KEPS #8-32
2	9781812	WELL NUT, #10-32	5	9785592	SCREW, TYPE F 5/16-18 X 1.25
3	9785073	STRIKE PLATE, CLAMP COVER	6	9781672	BUSHING - 1400

**PART NUMBERS LISTED MAY ONLY BE AVAILABLE IN KIT FORM OR AS AN ASSEMBLY**

Exploded Views, Continued..

...Exploded Views, Continued

## 8.6 Clamp Cover Assembly

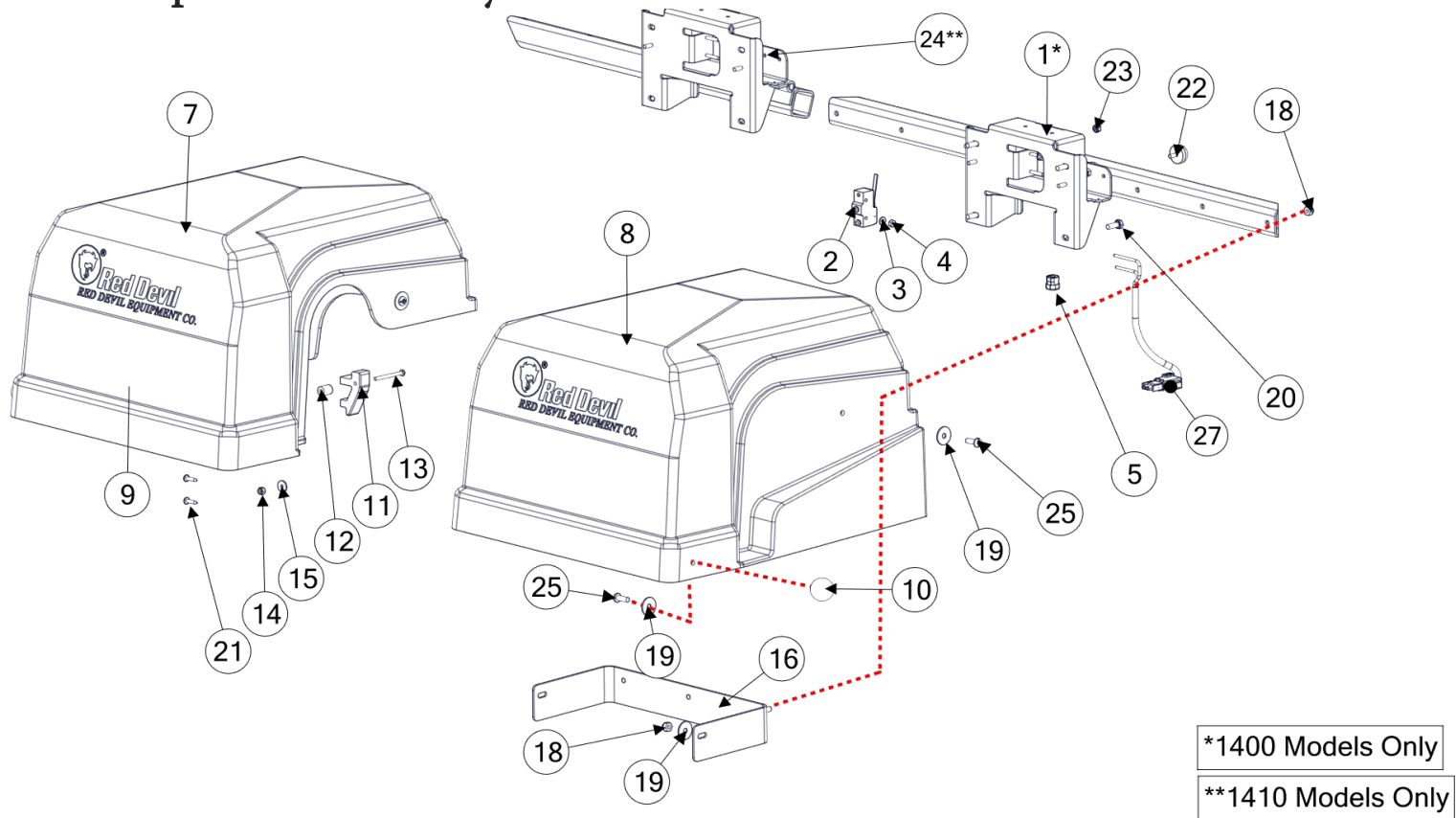

\*1400 Models Only  
\*\*1410 Models Only

ID	PART #	DESCRIPTION	ID	PART #	DESCRIPTION
1*	9785063	HINGE TUBE WELDMENT	14	9785126	NUT #8-32 NYLON LOCK
2	5783815	SWITCH, LIMIT 1HP	15	9785129	WASHER, FENDER #8 X .625
3	9784922	WASHER, FLAT #8	16	9785068	STUD PLATE, CLAMP COVER
4	9781840	NUT, KEPS #8-32	18	9780343	NUT 1/4-20 NYLON LOCK
5	9782457	STRAIN RELIEF	19	9781414	WASHER FENDER 1/4
7	9785002	CLAMP COVER, LEFT	20	9788085	SCREW, HEX SEMS 1/4-20 X .75 PATCH
8	9785003	CLAMP COVER, RIGHT	21	9785059	SCREW, TRUSS HD SHEET METAL #8 X .75
9	1785065	LABEL, WARNING CLAMP COVER	22	9785137	BUMPER, RUBBER, THRD STUD #10-32
10	9785066	HANDLE, RED BALL	23	9781383	NUT, NYLON LOCK #10-32
11	9785067	TENSION BLOCK, CLAMP COVER	24**	9785074	HINGE TUBE WELDMENT
12	9785124	SPACER, NYLON .635X.5X#10	25	9780827	SCREW, TRUSS, 1/4-20 X 3/4
13	9785125	SCREW, PH PAN HD 8-32 X 2.00	27	5785064	CABLE, LIMIT SWITCH

**PART NUMBERS LISTED MAY ONLY BE AVAILABLE IN KIT FORM OR AS AN ASSEMBLY**

...Exploded Views, Continued

## 8.7 Electrical Assembly PB

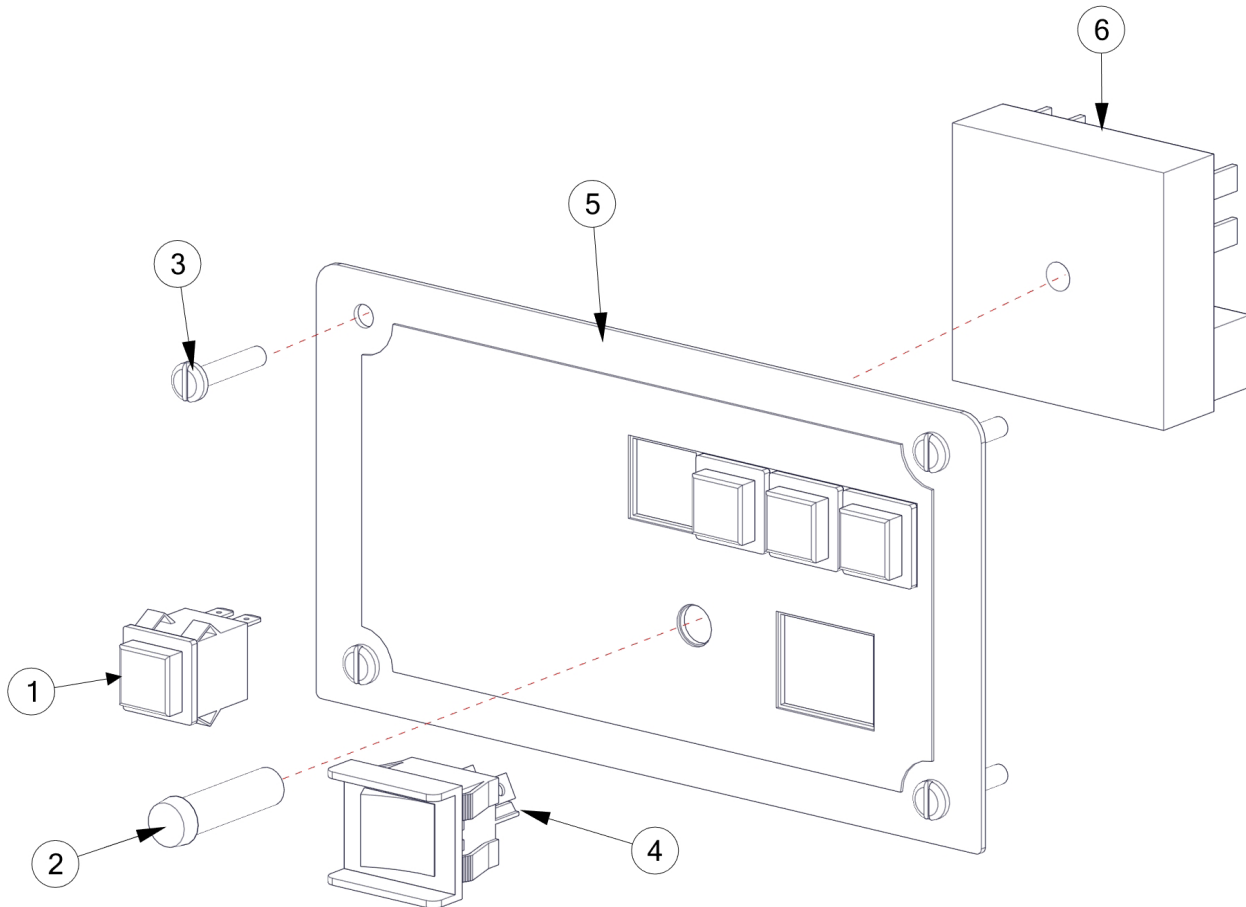

ID	PART #	DESCRIPTION	ID	PART #	DESCRIPTION
1	5782584	PUSH BUTTON, GREEN	4	5782445	POWER SWITCH
2	5782448	OPERATION LAMP, NEON	5	9782843	PUSH BUTTON TIMER PLATE
3	9781813	SCREW, PAN HD 10-32 X 1.00	6	5782894	CONTROLLER

**PART NUMBERS LISTED MAY ONLY BE AVAILABLE IN KIT FORM OR AS AN ASSEMBLY**

Exploded Views, Continued..

...Exploded Views, Continued

## 8.8 Electrical Assembly OO

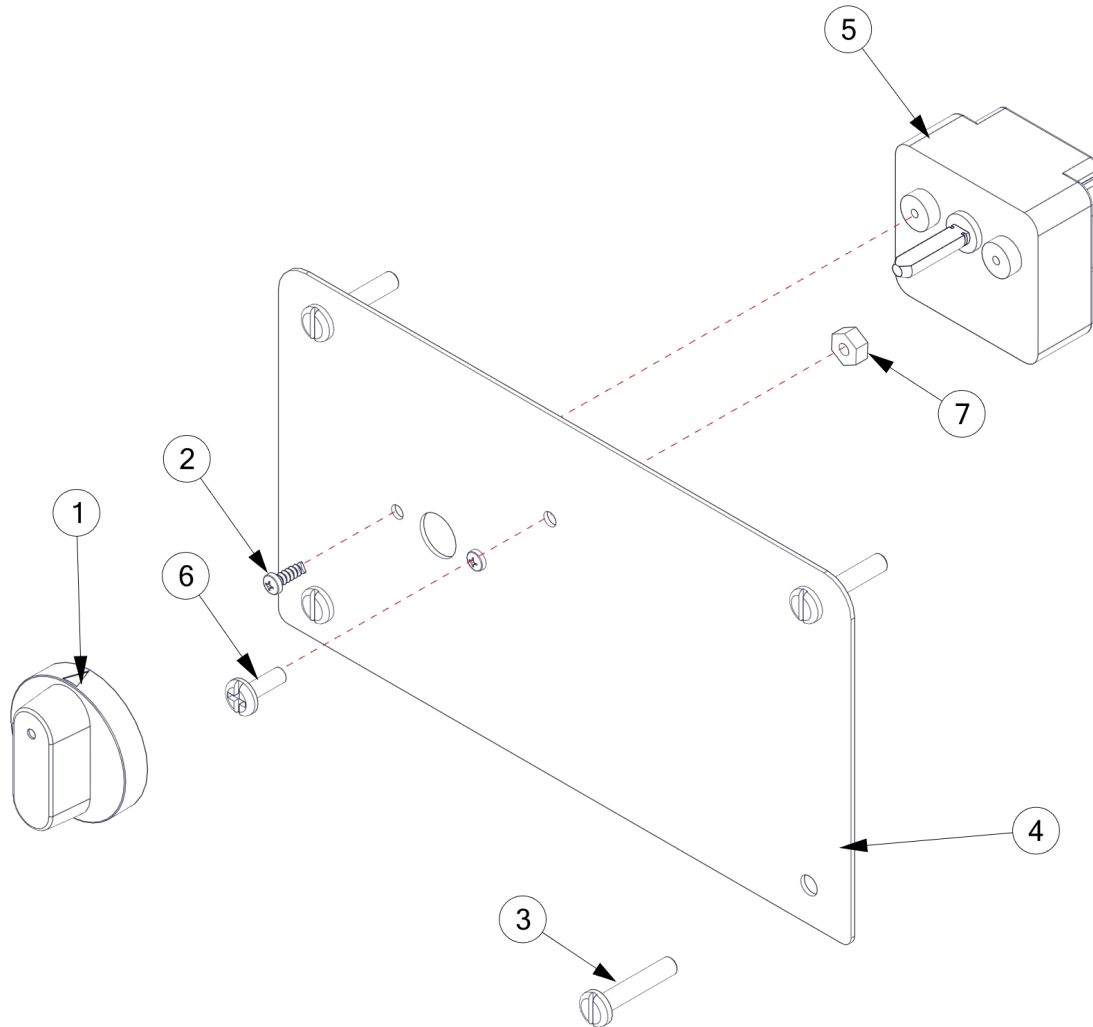

ID	PART #	DESCRIPTION
1	9756960	KNOB, TIMER
2	9784198	SCREW, PAN HD, PLASTITE #4 X .375 LG
3	9781813	SCREW, PAN HD 10-32 X 1.00
4	9790147	TIMER PLATE, 15 MIN, HOLD

ID	PART #	DESCRIPTION
5	No longer available See Digital Display for retro fit kit.	TIMER, 15 MIN, HOLD
6	9760537	SCREW, TRUSS HD PH 8-32 X 1/2
7	9781840	NUT, KEPS 8-32

**PART NUMBERS LISTED MAY ONLY BE AVAILABLE IN KIT FORM OR AS AN ASSEMBLY**

Exploded Views, Continued..

...Exploded Views, Continued

## 8.9 Electrical Assembly OH

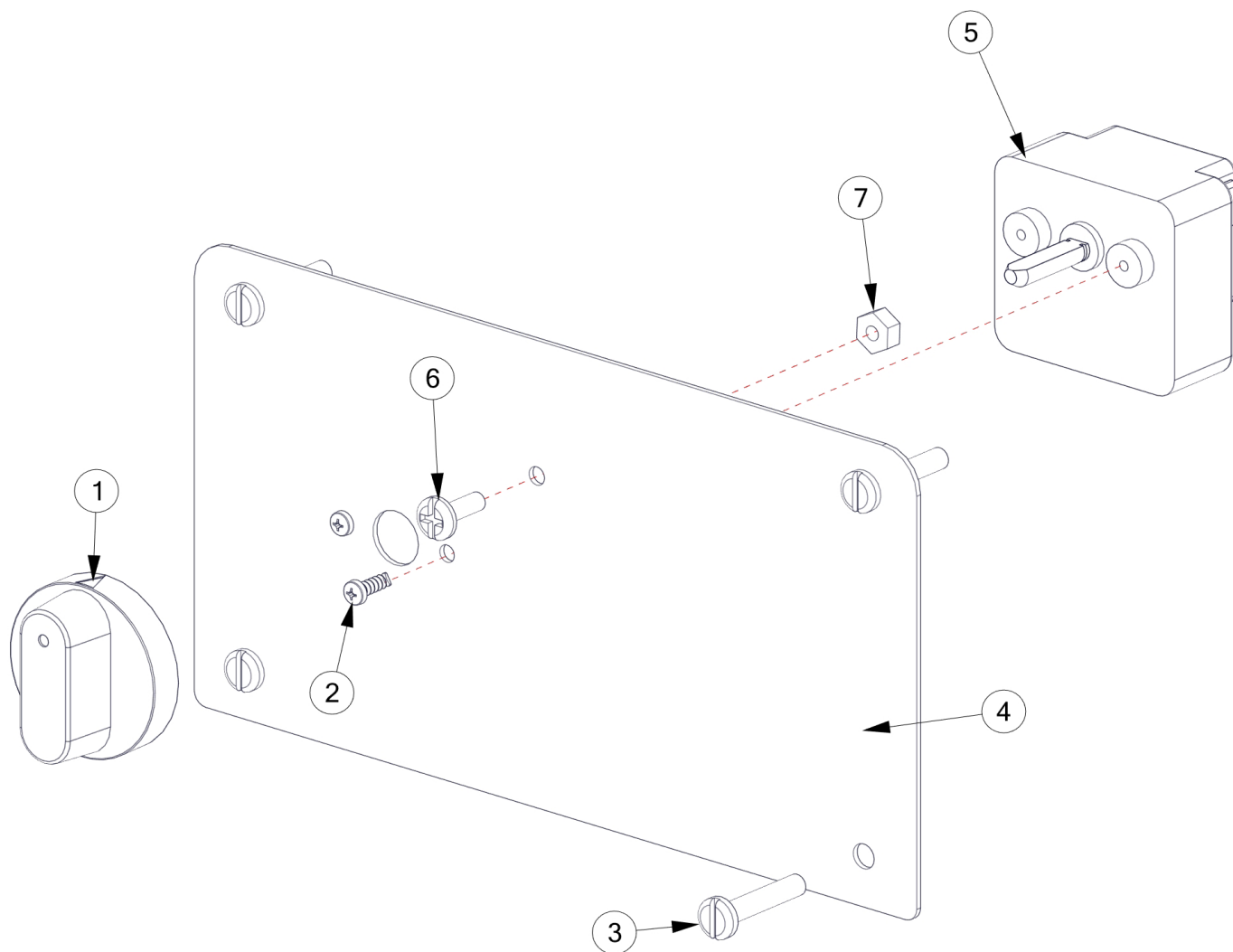

ID	PART #	DESCRIPTION
1	9756960	TIMER KNOB
2	9784198	SCREW, PAN HD THRD FORMING #4 X .38
3	9781813	SCREW, PAN HD 10-32 X 1.00
4	9622200	TIMER PLATE, 60 MINUTE

ID	PART #	DESCRIPTION
5	5758710	TIMER, 60 MINUTE
6	9760537	SCREW, TRUSS HD 8-32 X 1/2
7	9781840	NUT, KEPS 8-32

**PART NUMBERS LISTED MAY ONLY BE AVAILABLE IN KIT FORM OR AS AN ASSEMBLY**

Exploded Views, Continued..

...Exploded Views, Continued

## 8.10 Electrical Assembly Digital Display

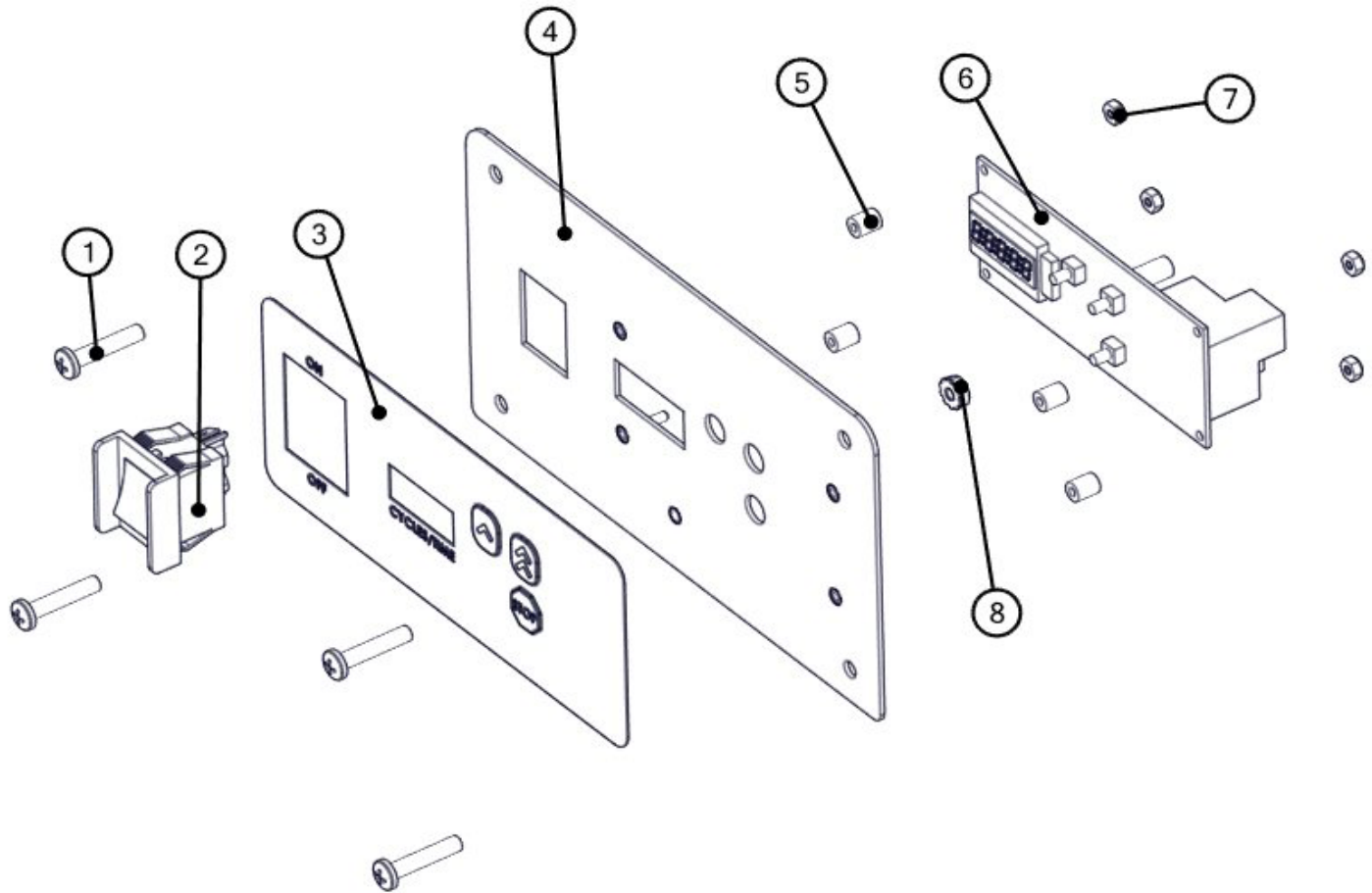

ID	PART #	DESCRIPTION	ID	PART #	DESCRIPTION
1	9781813	SCREW, PAN HD, 10-32 X 1.00	6	5786234	TIMER, DIGITAL, HORIZONTAL DISPL, 120V
2	5782445	POWER SWITCH	7	9783595	NUT, NYLOCK #4-40
3	1790286	LABEL, CONTROL PANEL -DD	8	9781840	NUT, KEPS 8-32 (FOR GROUND)
4	9790191	PLATE, CONTROL PANEL -DD	KIT	6790349	Retrofit kit to install DD timer onto 00 machines with 15 minute timer.
5	9786232	SPACER			

**PART NUMBERS LISTED MAY ONLY BE AVAILABLE IN KIT FORM OR AS AN ASSEMBLY**

Exploded Views, Continued..

...Exploded Views, Continued

## 8.11 Counter Base (5153-00)

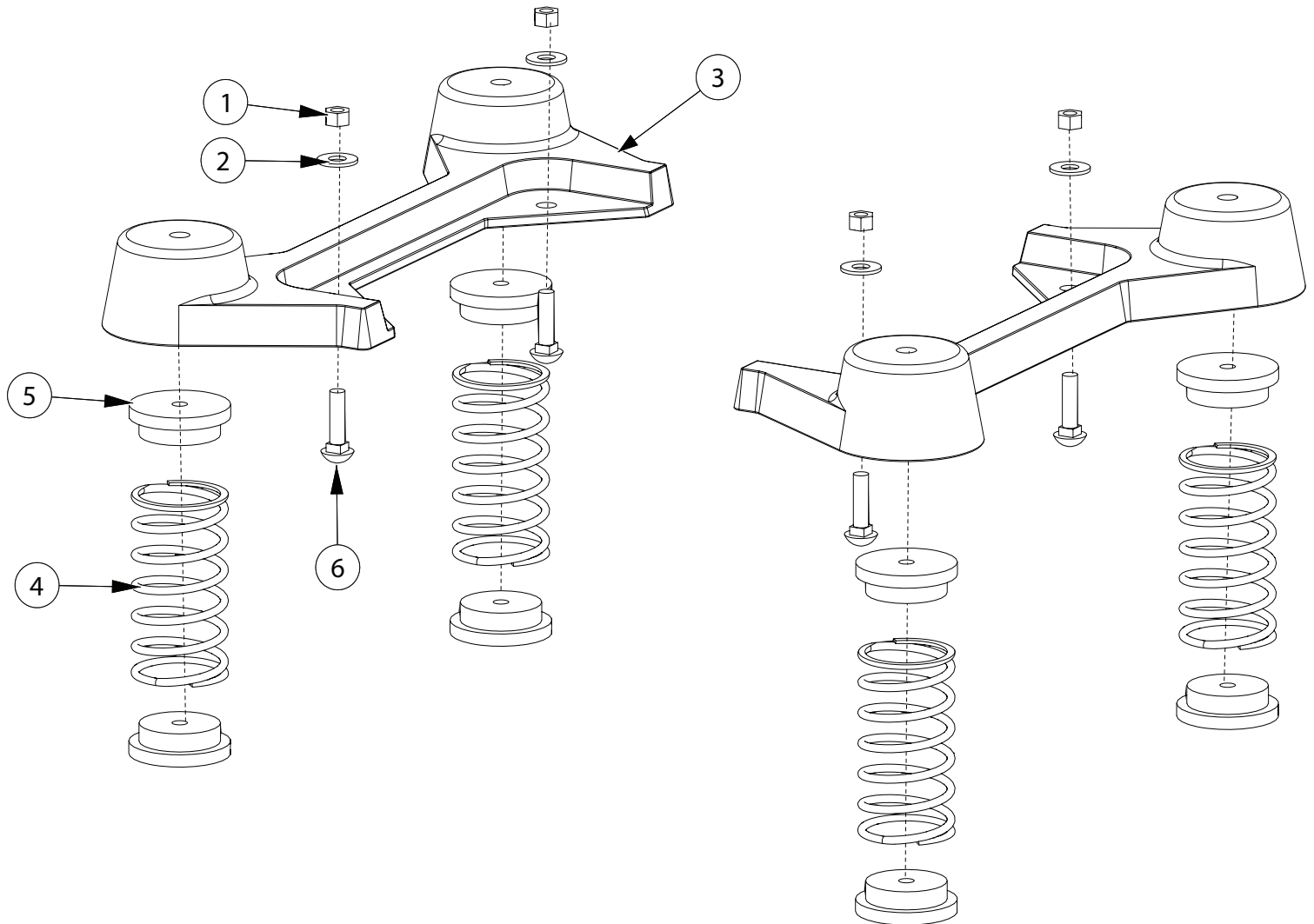

ID	PART #	DESCRIPTION
1	9389500	NUT, HEX 3/8-16
2	9161100	WASHER, FLAT 3/8 USS
3	9616500	COUNTER BASE

ID	PART #	DESCRIPTION
4	9190400	SPRING
5	9190300	FOOT, RUBBER
6	9190800	CARRIAGE BOLT 3/8-16 X 1.50

**PART NUMBERS LISTED MAY ONLY BE AVAILABLE IN KIT FORM OR AS AN ASSEMBLY**

Exploded Views, Continued..

...Exploded Views, Continued

## 8.12 Pedestal Base (5152-00)

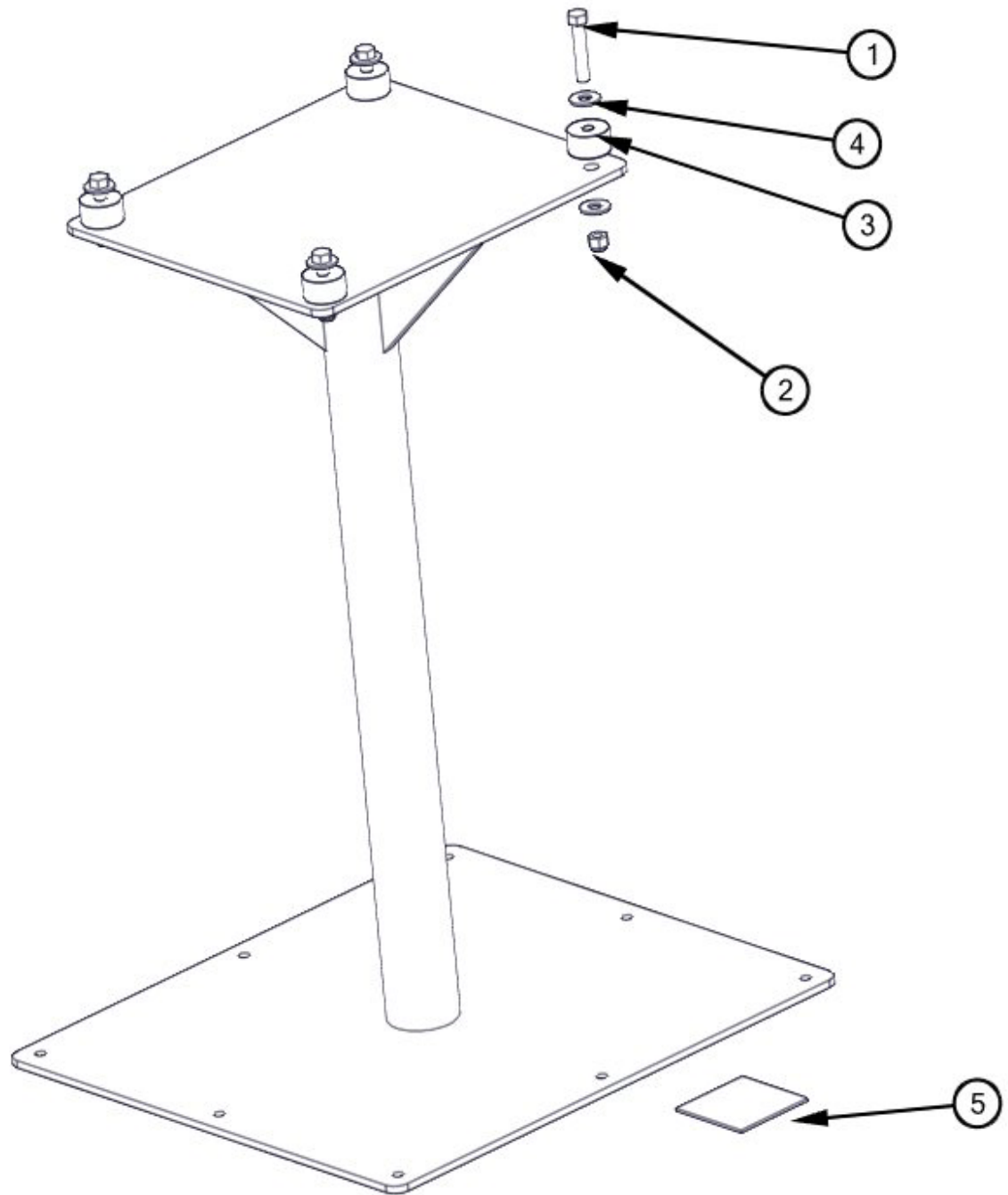

ID	PART #	DESCRIPTION
1	9780617	SCREW HED 3/8-16 X 2.00
2	9780193	NUT, NYLOCK 3/8-16
3	9327500	RUBBER FEET

ID	PART #	DESCRIPTION
4	9161100	WASHER, FLAT 3/8 USS
5	6787670	FEET, 3M VHB KIT (4 PADS AND INSTRUCTIONS)

**PART NUMBERS LISTED MAY ONLY BE AVAILABLE IN KIT FORM OR AS AN ASSEMBLY**

## 9. Ordering

### Replacement Parts

#### HOW TO ORDER REPLACEMENT PARTS

Replacement parts can be ordered from Radia by telephone, fax, or email:

#### RADIA

800-221-1083

763-533-2969

763-533-0015 (FAX)

orders@radiaproducts.com

If you need help in determining the proper part(s) to order, please call Customer Care. at 1-800-221-1083. Always indicate the Model and Serial numbers of the machine when ordering replacement parts.

#### GENERAL PARTS REPLACEMENT POLICIES

While your machine is under warranty, do not attempt on-site repair or parts replacement without first contacting RADIA. (to protect your warranty). After the warranty expires, replacement parts and recommendations for on-site servicing are available from RADIA. Please contact Customer Care for assistance.

#### RESTOCKING FEE

A restocking fee will be charged on all unused parts which are returned.



For instructional "How To" videos please visit:

[www.radiaproducts.com](http://www.radiaproducts.com)



## 10. Warranty

### Equipment Covered Under This Warranty

Models 1400 and 1410-PB, 1400 and 1410-DD, 1400 and 1410-OH, and 1400-OH-E5.

### Warranty

Radia warrants equipment manufactured by it and bearing its name to be free from defects in material and workmanship.

**EXCEPT FOR THE WARRANTY SET FORTH HEREIN, RADIA MAKES NO WARRANTY WHATSOEVER WITH RESPECT TO THE EQUIPMENT, INCLUDING ANY (a) WARRANTY OF MERCHANTABILITY; (b) WARRANTY OF FITNESS FOR A PARTICULAR PURPOSE; OR (c) WARRANTY AGAINST INFRINGEMENT OF INTELLECTUAL PROPERTY RIGHTS OF A THIRD PARTY; WHETHER EXPRESS OR IMPLIED BY LAW, COURSE OF DEALING, COURSE OF PERFORMANCE, USAGE OF TRADE OR OTHERWISE.**

This warranty applies only when the equipment is installed, operated and maintained in accordance with written Radia instructions as appearing in the owners' manuals.

This warranty does not cover, and Radia shall not be liable for, any malfunction, damage, or wear caused by faulty installation, misapplication, abrasion, corrosion, inadequate or improper maintenance, negligence, accident, tampering or substitution of non-Radia component parts, modification or use for non-intended purposes. Nor shall Radia be liable for malfunction, damage or wear caused by the incompatibility of Radia equipment with structures, accessories, equipment, or materials not supplied by Radia.

Subject to the limitations set forth above, Radia shall (i) repair or replace the equipment (or the defective part) or (ii) credit or refund the price of such equipment. Costs of labor and transportation for service of machines under this warranty will also be covered during the warranty period if Radia elects to repair or replace the equipment. Normal ground freight will be covered for replacement parts sent within the warranty period. For customers outside of the US and Canada, the warranty is for parts only. Ground or common carrier ground freight will be covered for the return of defective items only. In no case shall Radia's liability exceed the amount of the purchase price.

\*All warranty repairs must be executed by a Radia Authorized Service Center or warranty will be voided.

**THE REMEDIES SET FORTH HEREIN ARE PURCHASER'S SOLE AND EXCLUSIVE REMEDY and RADIA'S ENTIRE LIABILITY FOR ANY BREACH OF THE LIMITED WARRANTY SET FORTH HEREIN.**

Please contact your Radia Relationship Manager at 800-221-1083 for specific questions regarding specific questions regarding warranty terms.





For sales or service, please contact

RADIA

Attn: Customer Service Department

14900 21st Ave N

Plymouth, MN 55447

USA

**Fax:** 763.533.0015

**E-mail:** [info@radiaproducts.com](mailto:info@radiaproducts.com)

**Customer Service:** [customerservice@radiaproducts.com](mailto:customerservice@radiaproducts.com)

**Parts Orders:** [orders@radiaproducts.com](mailto:orders@radiaproducts.com)

**Technical Support:** [tech@radiaproducts.com](mailto:tech@radiaproducts.com)

[www.radiaproducts.com](http://www.radiaproducts.com)



For instructional "How To" videos please visit:  
[www.radiaproducts.com](http://www.radiaproducts.com)

