

# Owner's Manual: 05925 DynoMix X1 & X1U

Models 0-5925-X1, 0-5925-X1U

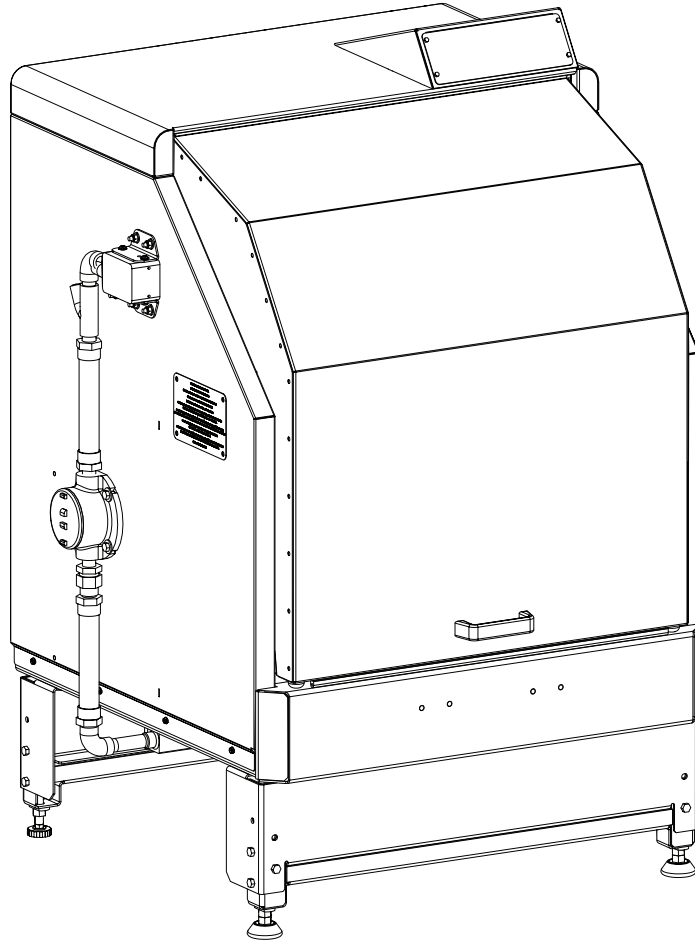



# Table of Contents

<b>1. Safety Information</b>	<b>3</b>	<b>7. Wiring Diagram</b>	<b>12</b>
1.1 Safety Precaution Labels	3-4	7.1 110 V 60 HZ	12
1.2 Safety Precaution Summary	5		
<b>2. Introduction</b>	<b>6</b>	<b>8. Exploded Views</b>	<b>13</b>
2.1 Application	6	8.1 Rotating Arm Lock Assembly	13
2.2 Specifications	6	8.2 Frame and Drive	14
2.2 Specifications Continued	7	8.3 Rotating Frame	15
		8.4 Rotating Clamp Belt	16
<b>3. Installation</b>	<b>8</b>	8.5 Rotating Frame Back	17
3.1 Prepare for Use	8	8.6 Lead Screw	18
3.2 Adjust the Risers	8	8.7 Ratchet Handle	19
3.3 Verify the Machine is Level	8	8.8 Riser Kit, X1U	20
		8.9 Feet X1	22
<b>4. Operation</b>	<b>9</b>	8.10 Electrical Exploded	23
4.1 Remote Switch	9	<b>9. Ordering</b>	<b>24</b>
4.2 Install a Pail and Mix	9	Replacement Parts	24
4.3 Remove a Pail	9		
<b>5. Care and Maintenance</b>	<b>10</b>	<b>10. Warranty</b>	<b>25</b>
5.1 Cleaning	10		
5.2 Maintenance	10	<b>11. Notes</b>	<b>26</b>
<b>6. Trouble Shooting</b>	<b>11</b>		

# 1. Safety Information

Review this owner's manual and read all warning labels on the machine prior to use.

The three main safety notifications used in this manual and on the warning labels are **WARNING**, **CAUTION** and **NOTICE**. They have specific meanings and indicate the potential dangers from misuse of the machine.

	<p><b>"WARNING!"</b> indicates a hazardous situation, which, if not avoided, could result in death or serious injury. These serious injuries could include permanent loss of function or significant disfigurement, disability, considerable pain and suffering, amputations, severe burns, and loss or impairment of vision or hearing. Take all necessary precautions to avoid unnecessary</p>
	<p><b>"CAUTION!"</b> indicates a hazardous situation, which, if not avoided, could result in minor or moderate injury.</p>
	<p><b>"NOTICE"</b> indicates practices that do not involve physical injury but may damage the machine.</p>

## 1.1 Safety Precaution Labels

**IMPORTANT !**

BEFORE RUNNING MACHINE, DID YOU....

- 1....POSITION CONTAINER PROPERLY
- 2....ATTACH THE BAIL SPRING
- 3....TIGHTEN CLAMP SECURELY



**WARNING**



**DO NOT RUN MACHINE EMPTY**

IMPORTANT MAINTENANCE ITEMS		
FREQUENCY	ITEM	MAINTENANCE
AS NEEDED	RATCHET LEVER	LUBRICATE MOVING PARTS WITH 3 IN 1 OIL.
AS NEEDED	BOTTOM PLATE	CLEAN OFF DIRT AND PAINT WITH HOT SOAPY WATER.
AS NEEDED	CLAMPING SCREW	LUBRICATE SCREWS WITH 3 IN 1 OIL.
AS NEEDED	LINKAGE ON DOOR	LUBRICATE BUSHING IN SLOT ON DOOR LINKAGE WITH 3 IN 1 OIL.
MONTHLY	MITER GEARS UNDER BOTTOM PLATE	GREASE WITH "OPEN GEAR & FIFTH WHEEL GREASE".
6 MONTHS	HEX SHAFT UNDER BOTTOM PLATE	CLOSE CLAMP & LUBRICATE THE LENGTH OF THE HEX SHAFT WITH 3 IN 1 OIL.
6 MONTHS	BAR SLIDE UNDER BOTTOM PLATE	TURN MIXING CRADLE UPSIDE DOWN & LUBRICATE WITH 3 IN 1 OIL.

Part No. 1785529

Safety Information, Continued..

	<b>WARNING</b> <b>ADVERTENCIA</b> <b>AVERTISSEMENT</b>
<ul style="list-style-type: none"> <li>- Machine must be properly grounded before use; improper grounding could cause electric shock and injury.</li> <li>-Disconnect power cord before servicing, cleaning or removing any cover, and follow lockout/ tagout procedures in owner manual; failure to disconnect power could cause electric shock and injury.</li> <li>-Review Owners Manual before installing or operating.</li> </ul>	
<ul style="list-style-type: none"> <li>- La maquinaria debe ser apoyada correctamente en el suelo antes de usar, el no apoyarla puede casuar choque eléctrico y daños.</li> <li>-Desconecte la energía antes de dar mantenimiento, limpiar o quitar cualquier cubierta, y siga los procedimientos de bloqueo/etiquetado del manual, Fallar en desconectar puede causar choque eléctrico y daños.</li> </ul>	
<ul style="list-style-type: none"> <li>- La machine doit e'tre correctement mis a' la terre avant de les utiliser mise a' la terre incorrecte peut provoquer un choc e'lectrique et de blessure.</li> <li>- De'branchez le cordon d'alimentation avant de proce'der a'l'entretien, le nettoyage ou le retrait des capots: suivez la proce'dure d'isolation/ consignation proce'dures dans le manul de l'opre'rateur; E'chec de</li> </ul>	

Part No. 1781570

<b>CAUTION</b>
<b>DO NOT OVER-TIGHTEN!</b>  <b>Tighten clamp up to 1/8 turn after contact with pail lid.</b>

Part No. 1785715

<b>WHEN MIXING: Make Sure Lever Is Completely Behind The Black Line.</b>  
<b>CAUTION</b>

Part No. 1785710

	<b>WARNING</b> <b>ADVERTENCIA</b> <b>AVERTISSEMENT</b>	<b>MOVING PARTS INSIDE</b> <b>PARTES EN MOVIMIENTO</b> <b>PIE'CES EN MOVEMENT</b>
<ul style="list-style-type: none"> <li>-Do not open door until machine comes to complete stop; moving parts inside could cause serious injury.</li> <li>-No abra la puerta hasta que la maquina se detenga completamente, las partes internas en movimiento pueden causar heridas graves.</li> <li>- Ne pas ouvrezla porte jusqu'a'ce que la machine esta comple'tement arre'te'; pièces en mouvement à l'intérieur pourrait provoquer des blessures grave.</li> </ul>		









Part No. 1784963

Safety Information, Continued..

Safety Information, Continued..





## 1.2 Safety Precaution Summary

### **WARNING!**

-  Be sure that the remote power switch is installed by a qualified electrician. Refer to local codes for proper placement of the remote power switch.
-  **DO NOT** attempt to replace any damaged electrical wire or components. Improper replacement could result in electric shock and serious injury. Only a qualified service representative should attempt to repair or replace any damaged electrical components.
-  Review this owner's manual before installing or operating.
-  The machine must be properly grounded prior to use. In the case of an electrical short circuit, grounding reduces the risk of electric shock by providing an escape wire for the electric current.
-  Check with a qualified electrician if you don't completely understand these grounding instructions, or if you are not sure whether the machine is properly grounded.
-  Follow the lockout/tagout procedures of your company.
-  **DO NOT** open the door until the machine comes to a complete stop.
-  Review product label, Material Safety Data Sheet, and HMIS rating of materials prior to mixing to determine potential hazards.
-  Machine is rated for Class I, Divisions 1 & 2, Groups C & D; Class II, Divisions 1 & 2, Groups E, F, & G locations.

-  “WARNING: This product may expose you to chemicals including DEHP, which is known to the State of California to cause cancer. For more information, go to [www.P65Warnings.ca.gov](http://www.P65Warnings.ca.gov)

### **CAUTION!**

-  Keep the work area free of clutter and electrical cords.
-  Use the proper power source. Refer to the machine data plate on the right side panel or the section 2.1, Specifications, in this manual.
-  **DO NOT** disable the limit switch. This switch interrupts power when the mixer door is opened.
-  Keep customers away from the work area. This machine should be used only by properly trained individuals.
-  Clamp the can carefully to ensure that it is held securely during the mixing cycle.

**Product safety labels should be inspected and cleaned periodically to maintain good legibility. Replace any labels that are no longer legible.**

## 2. Introduction

### 2.1 Application

Congratulations on your purchase of the 0-5925 Dynamix. This machine is designed to accommodate standard 1-gallon or 5-gallon plastic or metal containers weighing up to 100 lb. (45.4 kg).

Understand your machine's features and proper operation to take full advantage of its capabilities.

Read this entire manual completely before operating the machine. Practice installing and removing a container before mixing for the first time.

Keep this manual for future reference.

**Always follow all safety instructions!**

### 2.1 Specifications

**Unit Size:**

**X1U** W 35 in. (89 cm) D 34.25 in. (87 cm) H 53.5 to 57.5 in. (137 cm)

**X1** W 35 in. (89 cm) D 34.25 in. (87 cm) H 46.5 in. (116 cm)

**Unit Weight:** 450 lb. (204 kg)

**Electric Service, 5925-X1 & X1U:** 110 V 60 Hz

Machines rated at 110 V, 60 Hz are for use with a nominal 120 V circuit.

**Capacity:** 100 lb. (45.4 kg)

**Sizes Mixed:** 1 gal., 5 gal.

### X1U Dimensions

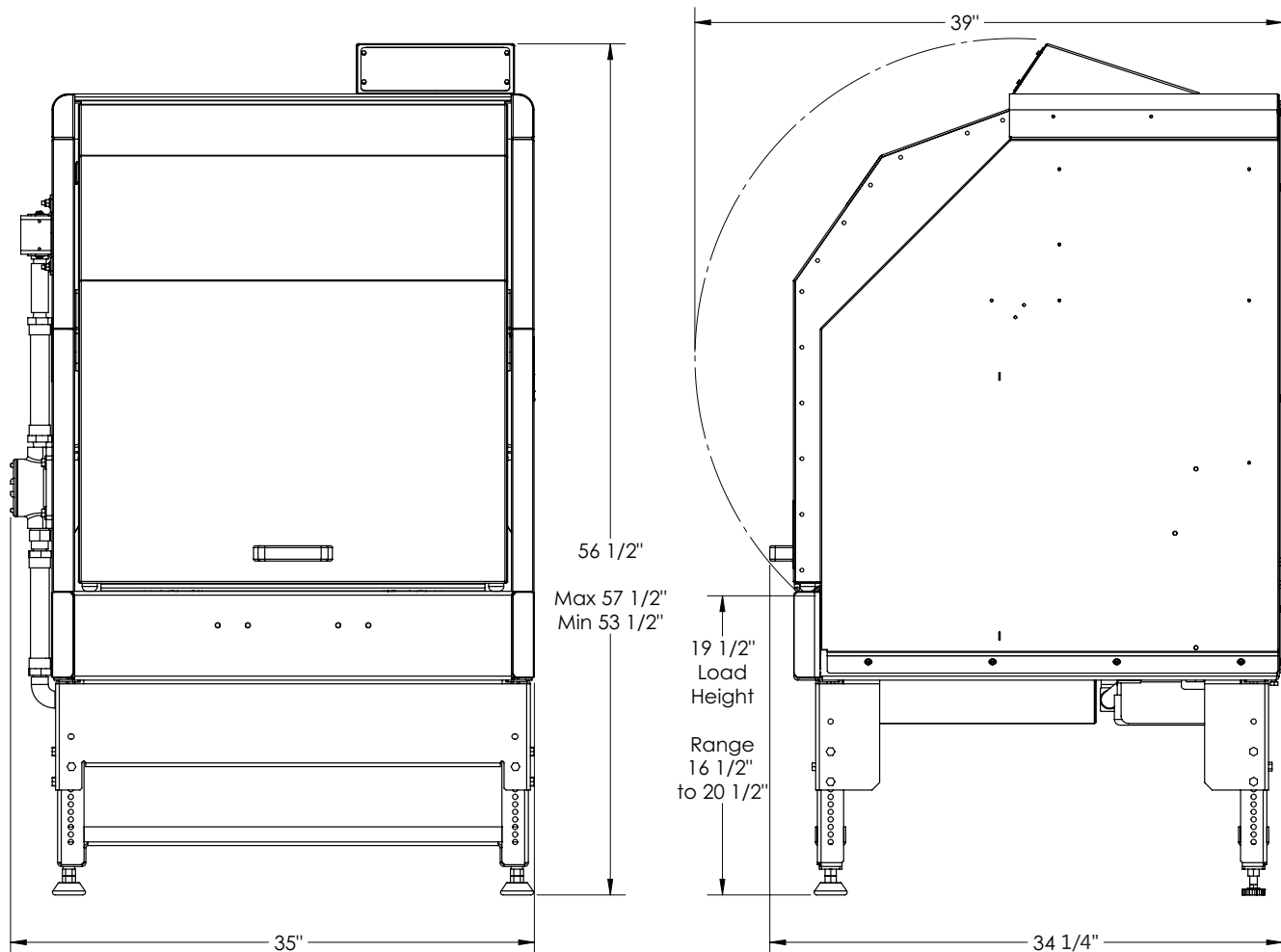

## 2.2 Specifications Continued

### X1 Dimensions

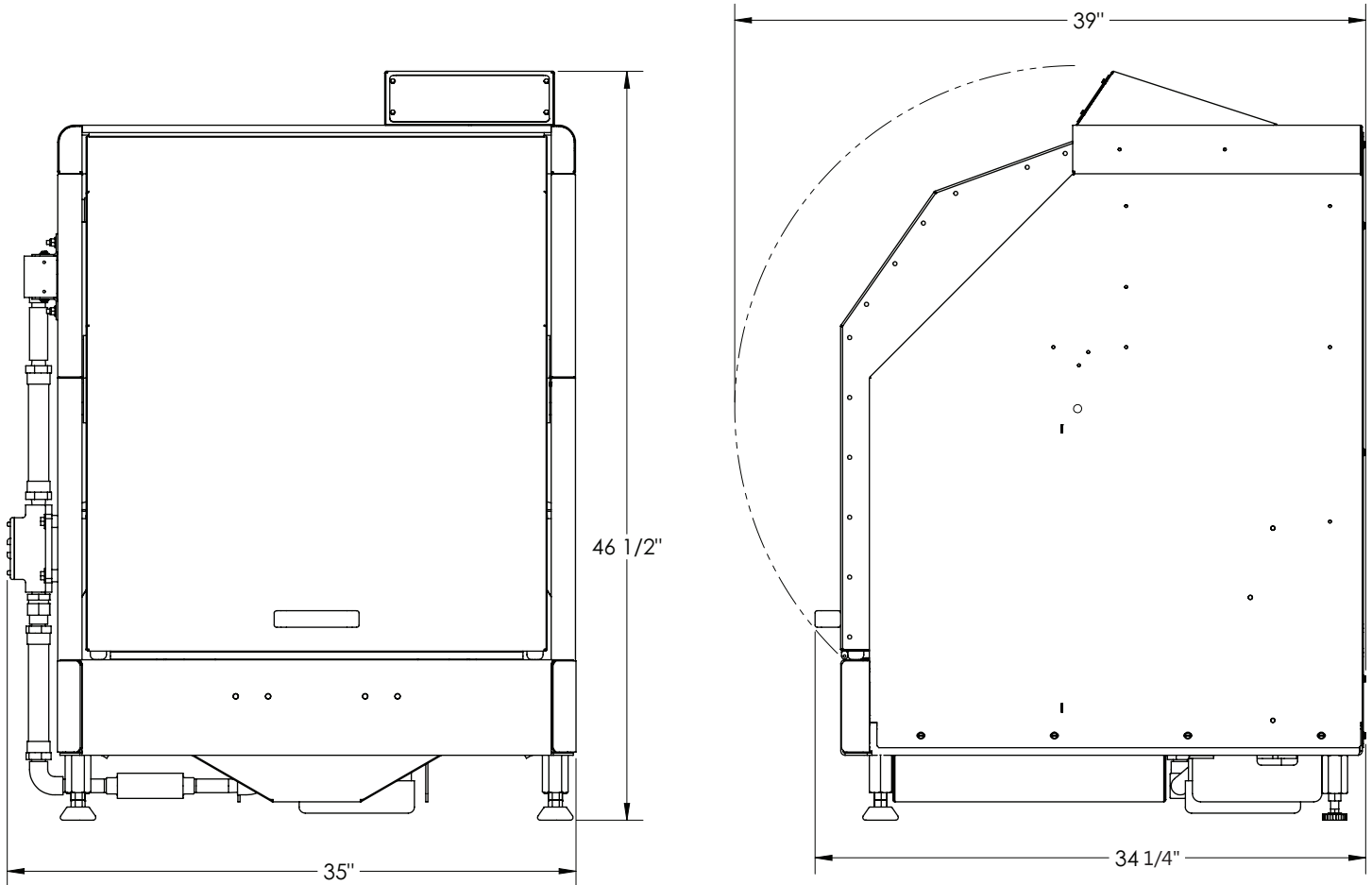

## 3. Installation

### 3.1 Prepare for Use

**⚠ WARNING!** Be sure that the remote power switch is installed by a qualified electrician. Refer to local codes for proper placement of the remote power switch.

**IMPORTANT:** Before attempting to operate the machine:

1. Remove all packing material.
2. Position the machine on a firm, level surface.
3. Follow the electrical connection

### 3.2 Adjust the Risers

**⚠ CAUTION!** Avoid personal injury! Be sure the machine is stable.

1. Loosen the screws **(A)**.
2. Adjust the crossbar **(B)** to the appropriate height.
3. Retighten the screws.

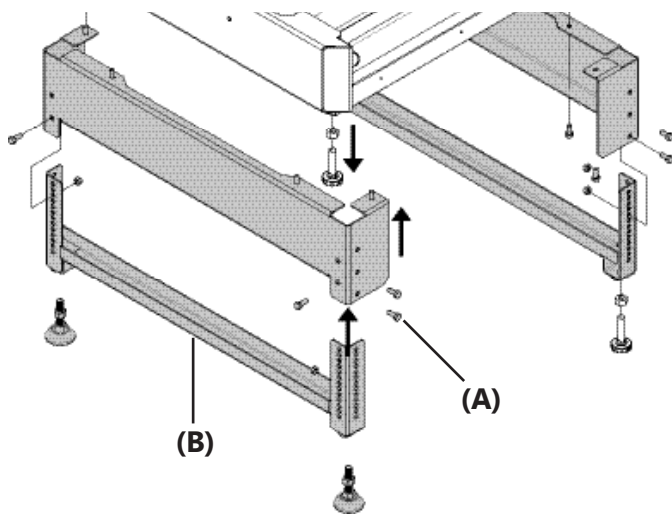

**X1 Foot**

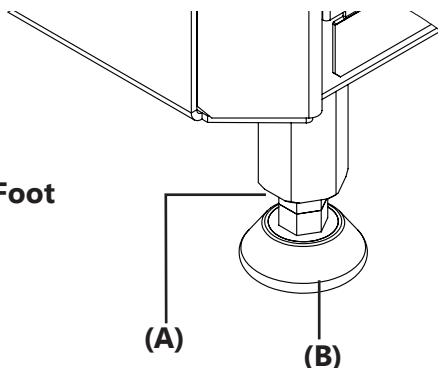

### 3.3 Verify the Machine is Level

1. Clamp a 5-gallon pail in the machine as per the instructions in Section 4.
2. Turn the machine on at the remote power switch..
3. Adjust any feet under which a piece of paper can fit.
  - a. Loosen the jam nuts **(A)**.
  - b. Turn the foot **(B)** to adjust.
  - c. Tighten the jam nut **(A)** when the foot makes full contact with the floor.
4. Repeat with any additional feet that may still need adjustment.

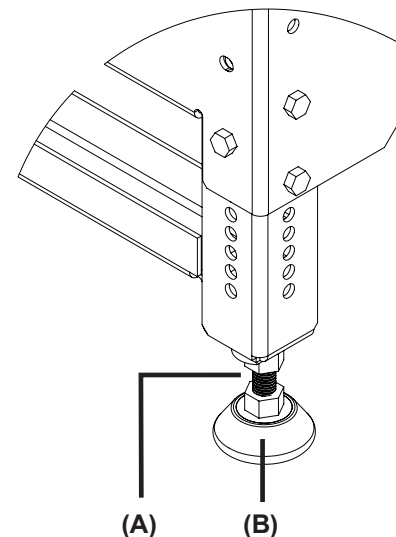
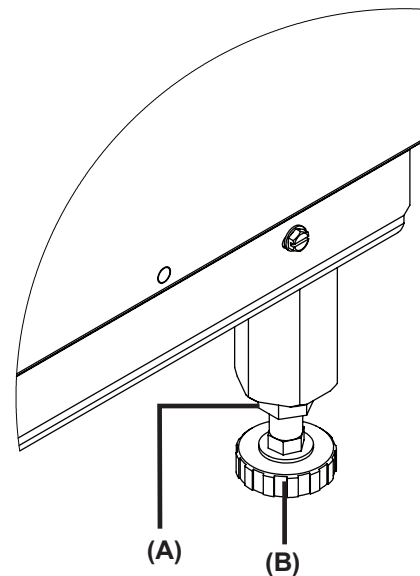



## 4. Operation

### 4.1 Remote Switch

The unit is wired into a **CUSTOMER** supplied remote switch. After the unit is loaded, the operator will turn the unit on and off at this remote switch.

### 4.2 Install a Pail and Mix

1. Open the cabinet door.
2. Pull the ratchet release lever **(A)** toward you until it clicks. Turn the handle **(B)** on the top of the clamp counterclockwise to raise the clamping (top) plate **(C)**.
3. Slide the pail onto the bottom plate **(D)**.
4. Position the pail in the grooves on the bottom plate. The grooves on the plate keep the pail in place during mixing.
5. Lower the clamping plate by turning the handle **(B)** clockwise. Once the plate makes contact with the pail, tighten another 1/8 turn.
6. Secure the bail with the bail spring.
7. Close the door and turn the machine on for the desired mix time.

▲ Notice: Avoid damage to the machine.

- A safety interlock interrupts machine operation if the door is open.
- If the bail spring wasn't properly secured, turn the power off and resecure after the machine stops. Do not operate the machine without a can installed.

### 4.3 Remove a Pail

▲ **WARNING!** Avoid serious personal injury. Do not open the door until the machine comes to a complete stop; moving parts inside could cause serious injury.

1. Raise the clamp all the way to the top by (1) pulling the ratchet release lever **(A)** toward you until it clicks and (2) turning the crank handle counter-clockwise.
2. Unfasten the bail spring.
3. Pull the pail forward onto the roller to remove from the machine.

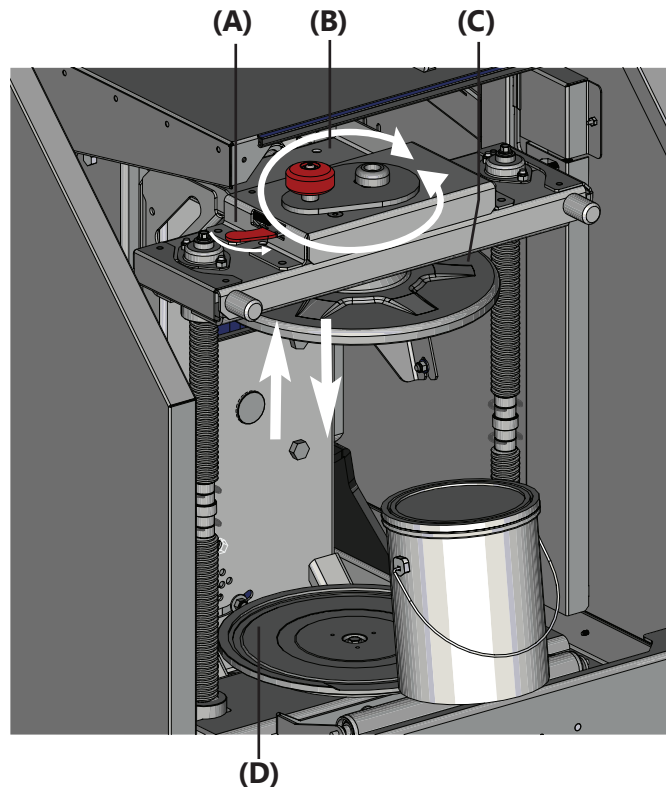

## 5. Care and Maintenance

**▲ WARNING!** Avoid electric shock. Always remove power from the machine per your company's lock out/tag out procedures before performing cleaning and maintenance tasks.

### 5.1 Cleaning

- Remove water-based/glycol colorants or base paints spilled on machine surfaces using lukewarm water and mild detergent.
- Do not use abrasives to clean machine surfaces. Doing so may damage the appearance of the machine,
- Keep the machine clean for reliable operation.

### 5.2 Maintenance

IMPORTANT MAINTANCE ITEMS		
FREQUENCY	ITEM	MAINTENANCE
As Needed	Ratchet Lever	Lubricate Moving Parts with 3 in 1 Oil
As Needed	Bottom Plate	Clean off Dirt and Paint With Hot Soap Water
As Needed	Clamping Screw	Lubricate Screws with 3 in 1 Oil
As Needed	Linkage on Door	Lubricate Bushing in Slot on Door Linkage with 3 In 1 Oil
Monthly	Miter Gears Under Bottom Plate	Grease with "Open Gear & Fifth Wheel Grease".
6 Months	Hex Shaft Under Bottom Plate	Close Clamp & Lubricate the Length of the Hex Shaft with 3 In 1 Oil.
6 Months	Bar Slide Under Bottom Plate	Turn Mixing Cradle Upside Down & Lubricate With 3 In 1 Oil

#### Lubrication:

1. **Speed Reducer:** Maintenance is not required. If an oil change is necessary:
  - a. Remove the oil drain plug on the bottom side of the machine and drain the oil from the gearbox.
  - b. Remove the oil level plug and fill only up to that level with Mobil SHC 634 Synthetic oil. Do not overfill or underfill.
2. **Clamp:** Lubricate the clamping screw threads and thrust bearing as needed with 3-in-1 oil.
3. **Ratchet Lever:** Lubricate the shaft as

## 6. Troubleshooting

PROBLEM	CAUSE	REMEDY
Machine won't operate	Not connected to power source	Connect to power source
	Building circuit breaker or fuse blown	Reset breaker or replace fuse
	Machine door does not make contact with limit switch	Read just switch to make contact with limit switch tab when door is closed
	Motor Thermal Protector Activated	Allow to cool, then restart
	Faulty Motor	Contact Radia Customer Care
	Worm, Damaged, or Loose drive belt	Unplug power cord, open mixer door, and visually inspect the drive belt.
Excessive Vibration	Pail damaged	Fix or replace pail
	Can Not properly seated	Reset pail into holder
	Feet are not level	Adjust and level feet
Machine doesn't shut off when door is opened	Faulty door limit switch	Contact Radia Customer Care
Increasing Mechanical noise	Bearings worn or damaged	Contact Radia Customer Care
Pail rotates inside the clamping plates	Top clamp pad worn	Replace top plate
	Top clamp not secure	Contact Radia Customer Care



## 8. Exploded Views

### 8.1 Rotating Arm Lock Assembly

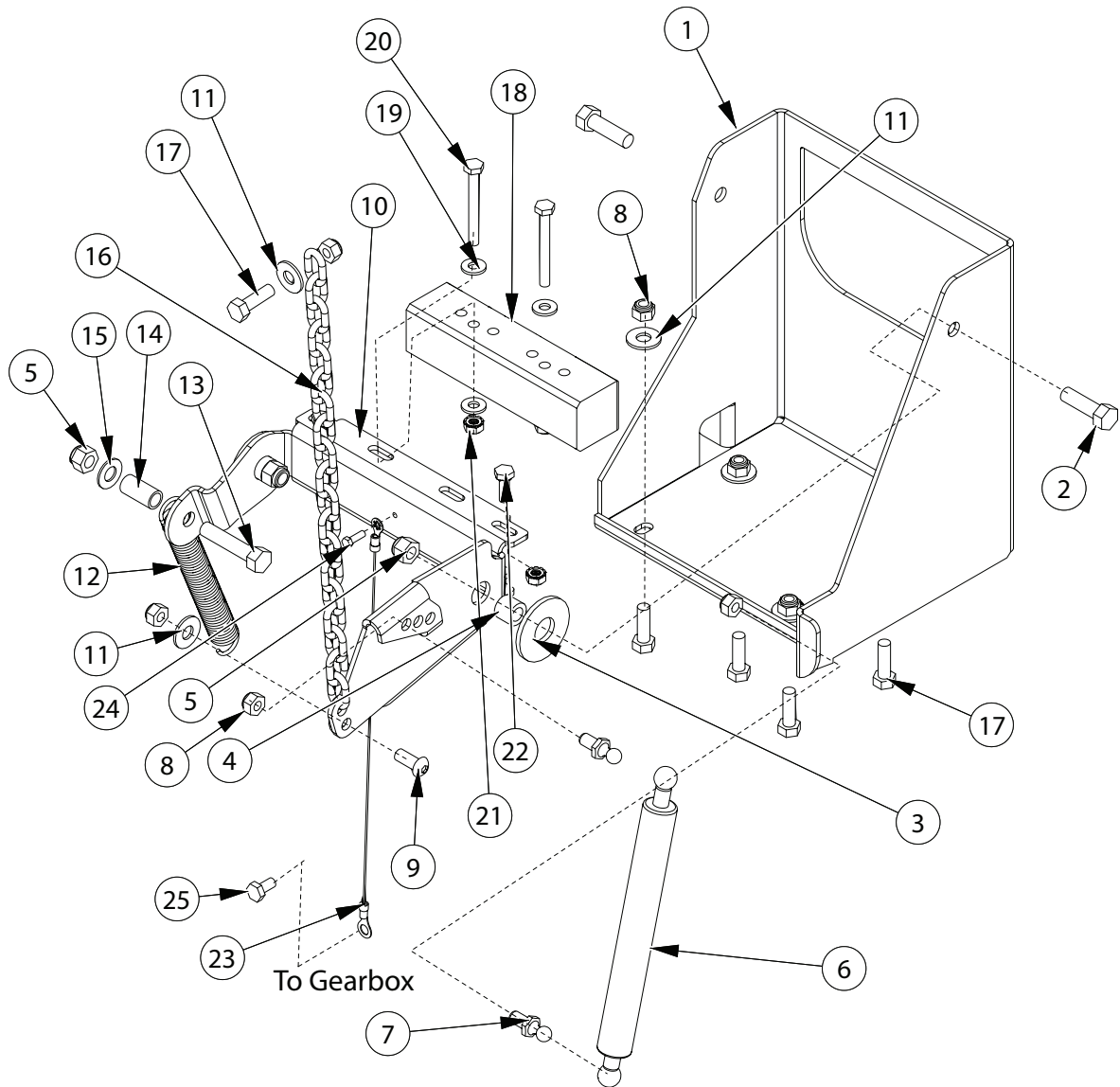

ID	Description
1	9785943 MOUNT, STOP LOCK, FLIP UP - 5925
2	9781228 Screw Hex 3_8 X 1 1_4
3	9785950 WASHER, FLAT .688 ID X 1.75 OD X .134 THK
4	9785951 BUSHING
5	9780193 Nut, Nylock 3_8-16
6	9785939 DAMPER, COMPRESSION, 100 LBS
7	9785709 BALL STUD
8	9780182 Nut, Nylock 5_16-18
9	9782904 Screw Button 5_16-18 x .75
10	9787085 BRACKET, BLOCK MOUNT, FLIP UP - 5925X1
11	9100023 WASHER, FLAT 5_16 USS
12	9785946 SPRING, EXTENSION
13	9785092 Screw Hex 3_8-16 X 1.75 FULL THD

ID	Description
14	9785945 BUSHING, BRONZE
15	9100731 WASHER, FLAT 3_8 X .82 OD
16	9785947 CHAIN
17	9561700 Screw Hex 5_16 X 1
18	9785544 BLOCK, ROTATING STOP
19	9760514 Washer 1_4 SAE .281 ID
20	9781541 Screw Hex 1_4 X 2 1_4
21	9785953 NUT, KEPS 1_4-20
22	9784555 SCREW, HEX SEMS 1_4-20 X .75
23	5787087 WIRE, GROUND, LONG - 5925X1
24	9781367 Screw Hex Thd Form #8 X .50
25	9787116 SCREW, HEX M8 X 1.25 X 10

**PART NUMBERS LISTED MAY ONLY BE AVAILABLE IN KIT FORM OR AS AN ASSEMBLY**

Exploded Views, Continued..

...Exploded Views, Continued

### 8.1 Frame and Drive

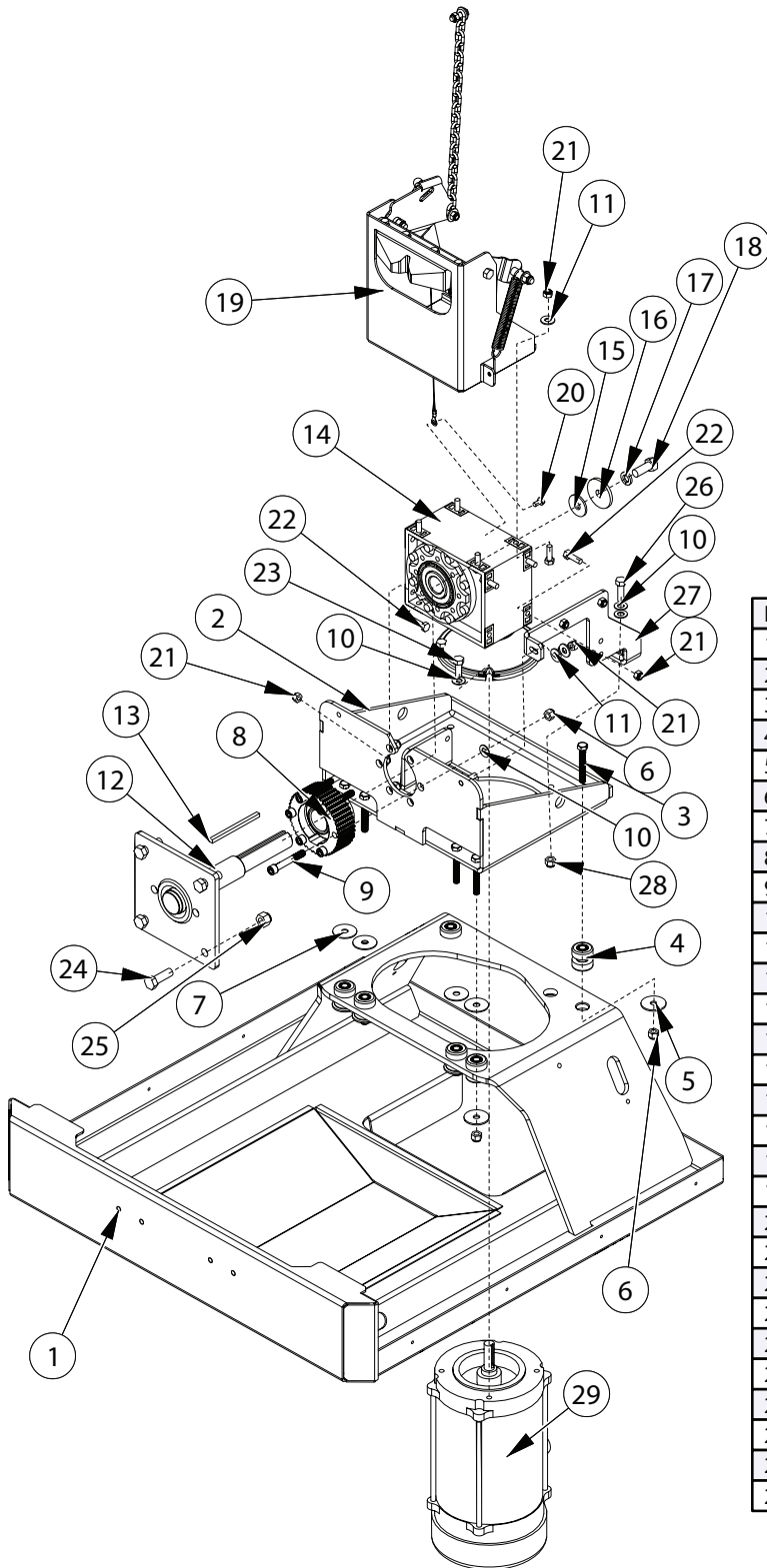

ID	Description
1	9786804 BASE WELDMENT - 5925-5025
2	9786861 MOUNT, GEARBOX - 5925
3	9783894 Screw Hex 3_8-16 x 2.50 Full Thd
4	9780367 Isolator set
5	9780368 Washer
6	9780193 Nut, Nylock 3_8-16
7	9786768 WASHER, FLAT, .406 ID X 1.50 OD X .062 TH, SS
8	9786132 PULLEY, STATIONARY TIMING, WITH BRG ASBY
9	9785781 SCREW, SOCKET HEAD CAP 3_8-16 X 2.50
10	9100731 WASHER, FLAT 3_8 X .82 OD
11	9100023 WASHER, FLAT 5_16 USS
12	9785368 SHAFT, TUMBLE - 5925
13	9785585 KEY, SQUARE .250 X 4.125
14	9785464 GEARBOX, RIGHT ANGLE SPEED REDUCER
15	9785587 WASHER, FLAT .512 ID X 1.456 OD X .118 THK
16	9781083 Washer, Flat .507 ID x 2.00 OD x .19 Thk
17	9780214 Washer 1_2 LOCK
18	9785780 SCREW, HEX 1_2-13 X 1.25 LG
19	6787053 STOP BLOCK ASBY, - 5925X1
20	9787116 SCREW, HEX, M8X1.25 X 10
21	9780182 Nut, Nylock 5_16-18
22	9561700 Screw Hex 5_16 X 1
23	9780886 SCREW HEX 3_8-16 X 1.00
24	9782154 Screw Hex 1_2 X 1_50
25	9783383 Nut 1_2 Nylon Lock
26	9781228 Screw Hex 3_8 X 1_4
27	9786862 BRACE, GEARBOX - 5925
28	9780193 NUT, NYLOCK 3_8-16
29	5786182 Motor, X-PROOF, 1 HP, 56C

**PART NUMBERS LISTED MAY ONLY BE AVAILABLE IN KIT FORM OR AS AN ASSEMBLY**

Exploded Views, Continued..

...Exploded Views, Continued

### 8.3 Rotating Frame

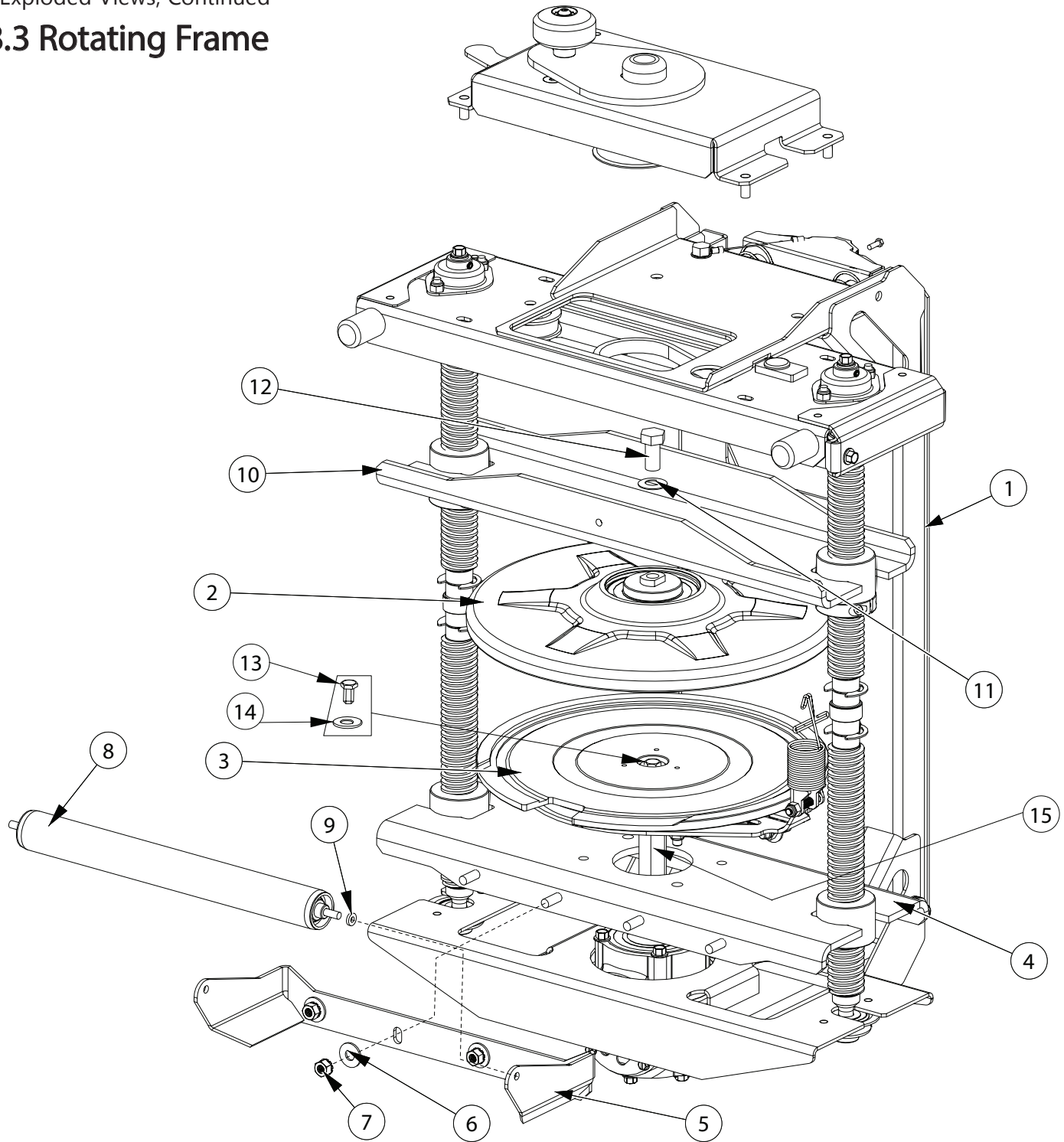

ID	Description
1	9785348 ROTATING FRAME WELD'T - 5925
2	6785936 TOP PLATE AND BEARING ASSY - 5925
3	6785825 BOTTOM PLATE ASBY, NOTCHED - 5925
4	9785341 CHANNEL, BOTTOM PLATE - 5925
5	9785342 BRACKET, ROLLER - 5925
6	9100023 WASHER, FLAT 5_16 USS
7	9785782 NUT, KEPS 5_16-18

ID	Description
8	9782520 ROLLER
9	9785537 WASHER, NEO, .195 ID, .438 OD, .093T
10	9785340 CHANNEL, TOP PLATE - 5925
11	9786096 WASHER, BELLVILLE, 1.000 OD X .505 ID X .067 TH
12	9780221 SCREW HEX 1_2-13 X 1.00
13	9787321 SCREW HEX 5_16-18 x .50
14	9787320 Flat Washer 5/16 x 1.0x .050 stainless
15	6787326 Hex Shaftleit

**PART NUMBERS LISTED MAY ONLY BE AVAILABLE IN KIT FORM OR AS AN ASSEMBLY**

Exploded Views, Continued..



...Exploded Views, Continued

### 8.3 Rotating Clamp Belt

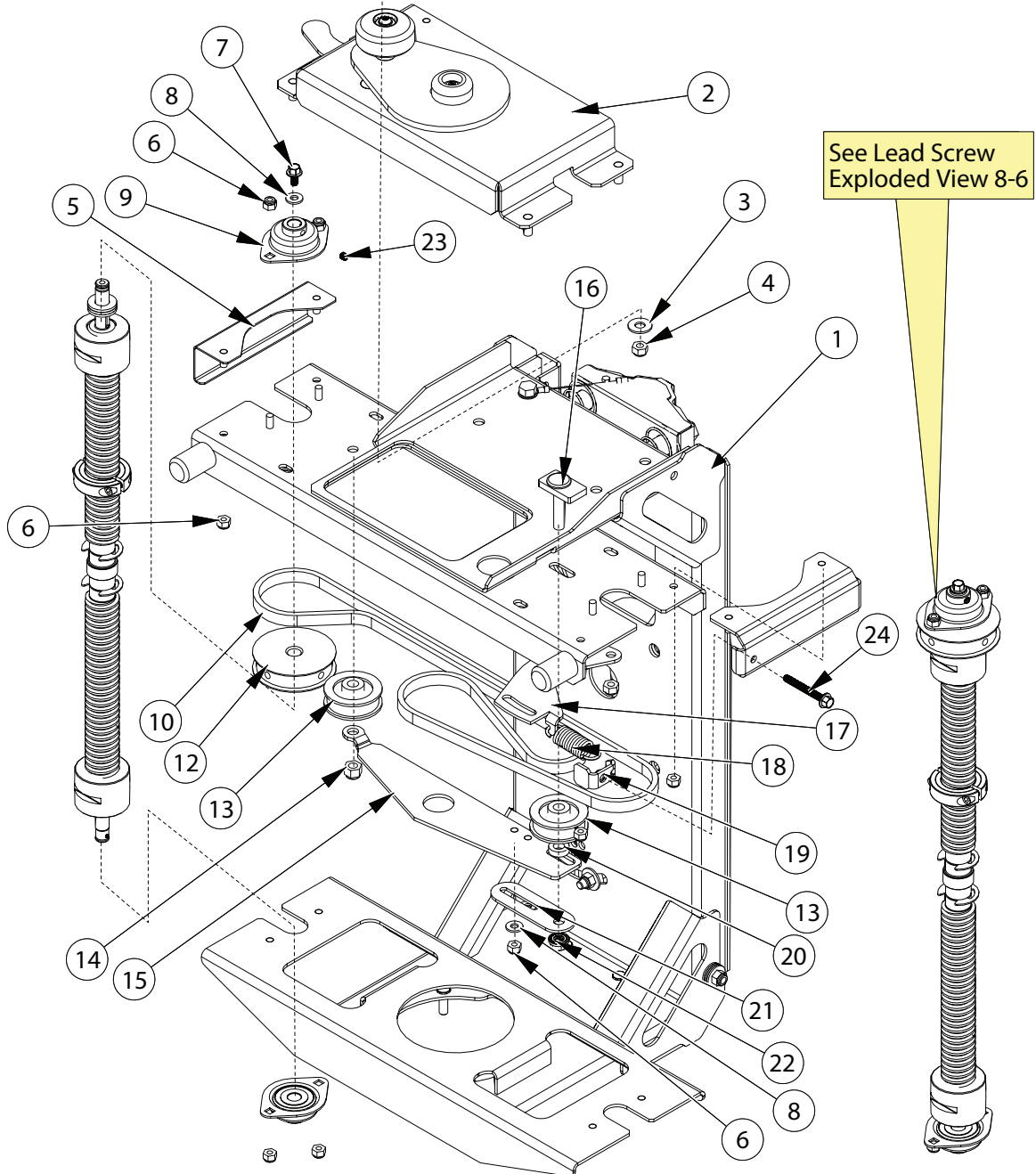

ID	Description
1	9785348 ROTATING FRAME WELD'T - 5925
2	6786165 RATCHET ASSEMBLY - 5925
3	9100023 WASHER, FLAT 5_16 USS
4	9780182 Nut, Nylock 5_16-18
5	9785531 COVER, LEAD SCREW PULLEY - 5925
6	9780343 Nut 1_4-20 Nylon Lock
7	9785779 SCREW, SERRATED FLANGE HEX HD, .25-20 X .50 LG
8	9760514 Washer 1_4 SAE .281 ID
9	9785434 BEARING, FLANGED 2-BOLT
10	9786081 BELT, TIMING, CLAMP - 5925
12	9786079 PULLEY, TIMING, LEAD SCREW, S8M-28T - 5925
13	9785406 IDLER, CLAMP BELT, TENSION, - 5925X1

ID	Description
14	9780193 Nut, Nylock 3_8-16
15	9786101 BRACE, BOTTOM, CLAMP BELT - 5925
16	9786102 TENSIONER, CLAMP BELT - 5925
17	9786100 TENSION ARM, CLAMP BELT - 5925
18	9786117 SPRING, TENSION, CLAMP BELT - 5925
19	9786114 TAB, TENSIONER, U CHANNEL
20	9786091 SPACER, 3_8 BOLT
21	9786099 BRACE, SECONDARY, CLAMP BELT - 5925
22	9786098 NUT, FLANGED, SERRATED, HEX 3_8-16
23	SCREW, SET, KNURLED CUP POINT 1_4-28 X .25 (PART OF ITEM 9)
24	9786118 SCREW, SER FLANGE HEX HD, .25-20 X 2.00 LG FULL THD

**PART NUMBERS LISTED MAY ONLY BE AVAILABLE IN KIT FORM OR AS AN ASSEMBLY**

Exploded Views, Continued..



...Exploded Views, Continued

### 8.5 Rotating Frame - Back

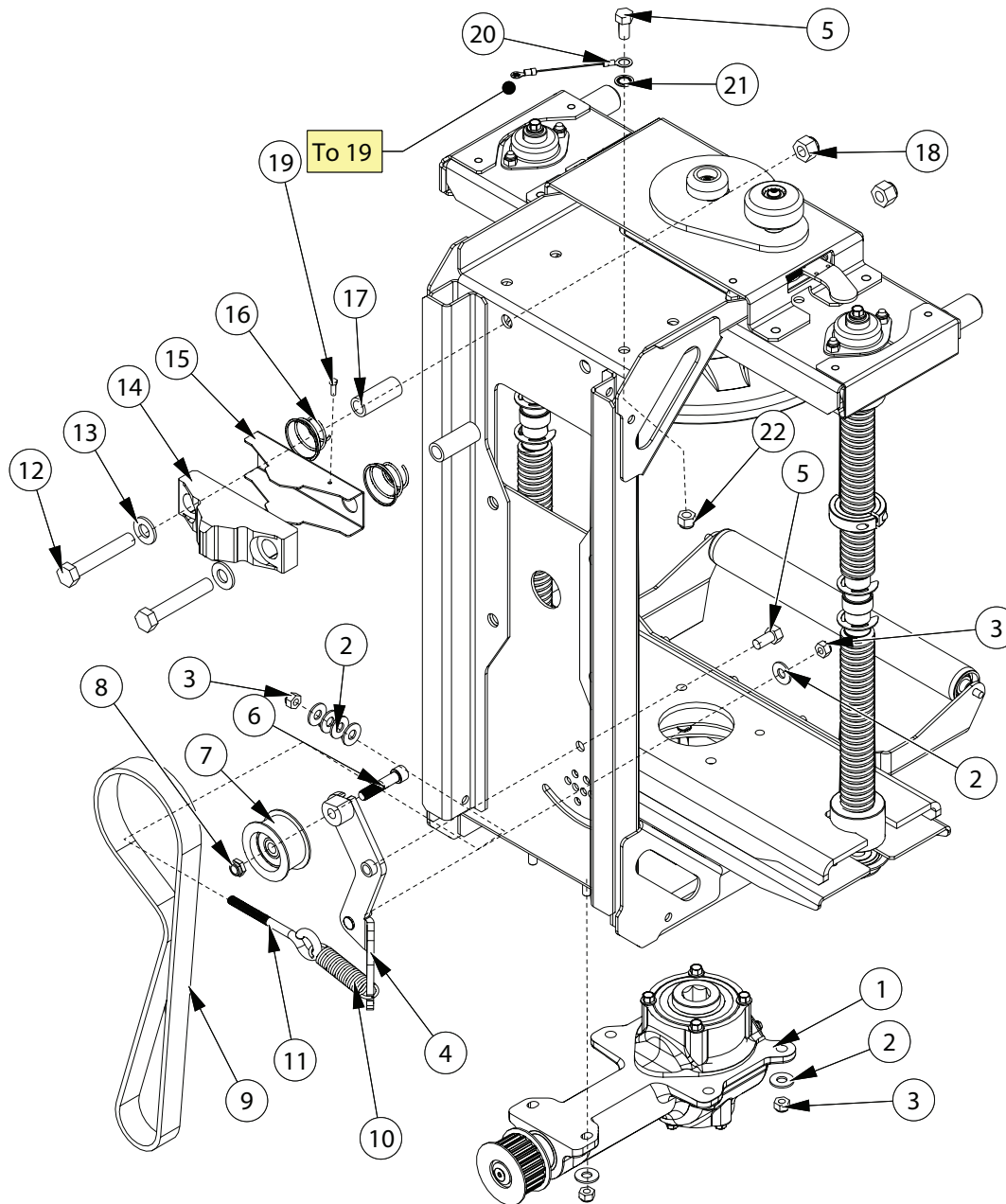

ID	Description
1	6786544 MITER GEARBOX ASSY - 5925
2	9100023 WASHER, FLAT 5_16 USS
3	9780182 Nut, Nylock 5_16-18
4	9786134 TENSIONER ARM, SPRING ACTUATED, S8M - 5925
5	9780144 Screw Hex 3_8-16 x .75
6	9785783 SCREW, SOCKET HEAD CAP, 3_8-16 X 1.75
7	9787062 IDLER, SPIN DRIVE TENSION, ESD - 5925
8	9783951 Nut, 3_8-16 Jam Nylon Lock
9	9786131 BELT, TIMING, DRIVE, S8M - 5925
10	9786086 SPRING, TENSION, DRIVE - 5925
11	9786090 BOLT, EYE 5_16-18 X 3.5 LG
12	9784919 Screw Hex 1_2-13 X 3

ID	Description
13	9784746 WASHER, FLAT, 1_2 HARDENED
14	9785545 PIN, ROTATING STOP
15	9787074 SHIELD, PIN - 5925-X1
16	9785551 SPRING, COMPRESSION, TAPERED - 5925
17	9785437 BUSHING, SPRING, STOP BLOCK - 5925
18	9783383 Nut 1_2 Nylon Lock
19	9781367 Screw Hex Thd Form #8 X .50
20	5787086 WIRE, GROUND, SHORT - 5925X1
21	9163000 WASHER, LOCK, INT TOOTH, 3/8
22	9780193 NUT, NYLOCK 3_8-16

**PART NUMBERS LISTED MAY ONLY BE AVAILABLE IN KIT FORM OR AS AN ASSEMBLY**

Exploded Views, Continued..

...Exploded Views, Continued

### 8.6 Lead Screw

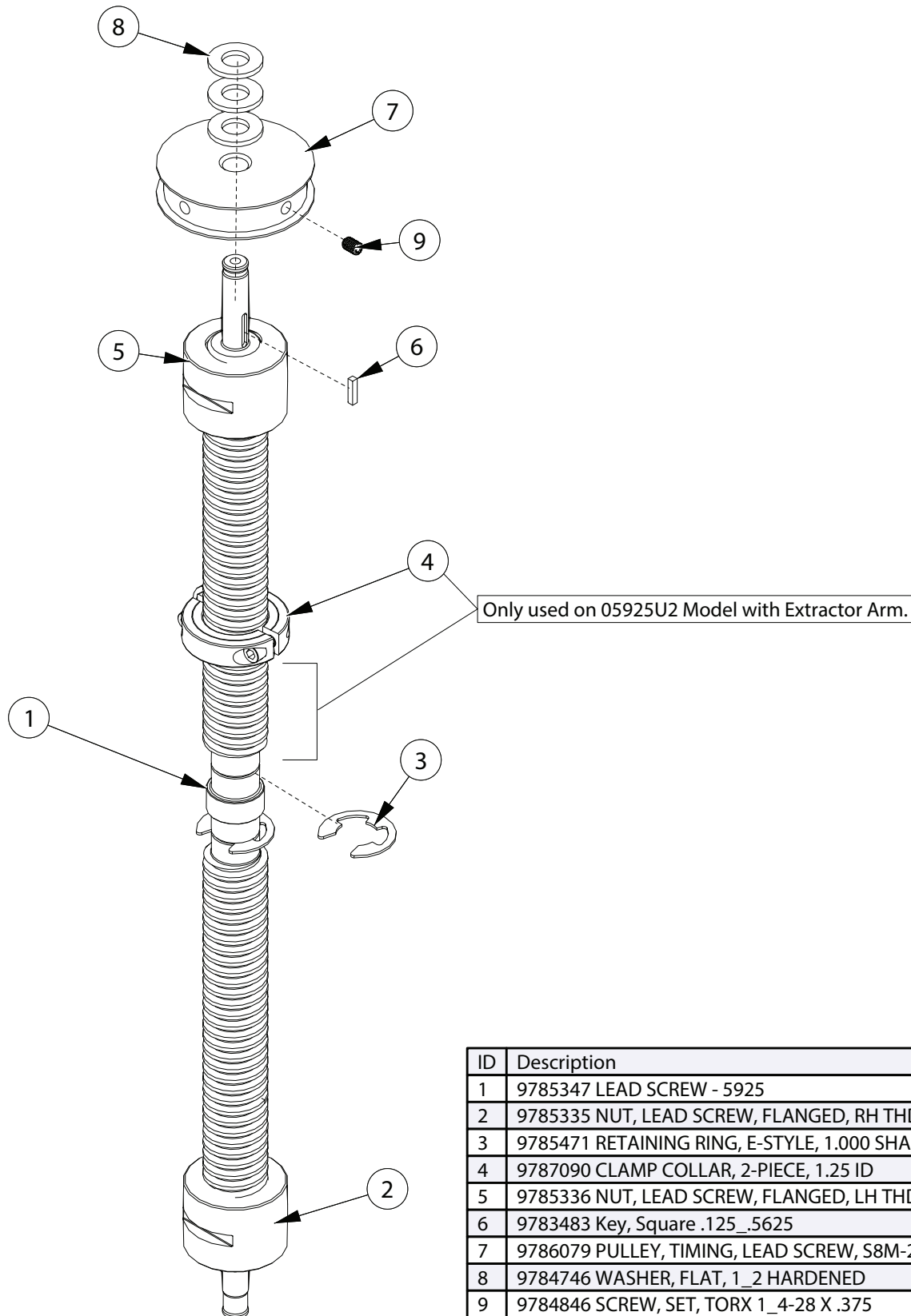

ID	Description
1	9785347 LEAD SCREW - 5925
2	9785335 NUT, LEAD SCREW, FLANGED, RH THD - 5925
3	9785471 RETAINING RING, E-STYLE, 1.000 SHAFT
4	9787090 CLAMP COLLAR, 2-PIECE, 1.25 ID
5	9785336 NUT, LEAD SCREW, FLANGED, LH THD - 5925
6	9783483 Key, Square .125_.5625
7	9786079 PULLEY, TIMING, LEAD SCREW, S8M-28T - 5925
8	9784746 WASHER, FLAT, 1_2 HARDENED
9	9784846 SCREW, SET, TORX 1_4-28 X .375

**PART NUMBERS LISTED MAY ONLY BE AVAILABLE IN KIT FORM OR AS AN ASSEMBLY**

Exploded Views, Continued..

...Exploded Views, Continued

### 8.7 Ratchet Handle

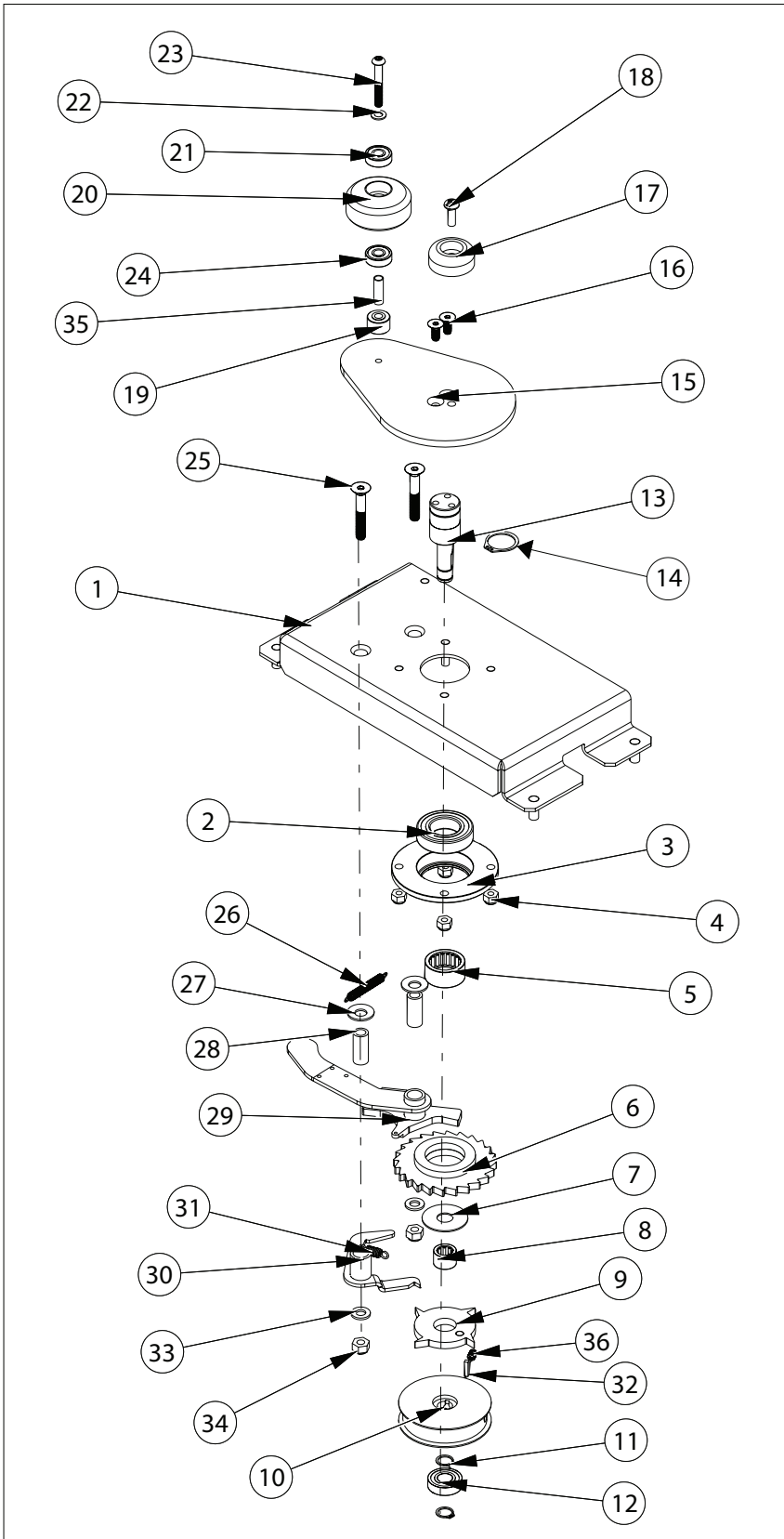

ID	Description
1	9785386 PLATE, RATCHET MOUNT - 5925
2	9785467 BEARING, RADIAL BALL 25 MM X 47 MM X 12 MM
3	9785387 HOUSING, RATCHET BEARING - 5925
4	9780343 Nut 1_4-20 Nylon Lock
5	9785466 BEARING, 1 WAY NEEDLE-ROLLER, 1.00 SHAFT
6	9785389 COG, RATCHET LARGE BORE - 5925
7	9785538 WASHER, .531 ID 1.5 OD .047 THK
8	9785465 BEARING, 1 WAY NEEDLE-ROLLER, .500 SHAFT
9	9785390 COG, RATCHET - 5925
10	9786080 PULLEY, TIMING RATCHET, S8M-28T - 5925
11	9786097 RETAINING RING, EXT., .500 Shaft
12	9786095 BEARING, RADIAL BALL .500 X 1.125 X .3125
13	9786094 SHAFT, CLAMP HANDLE, LONG - 5925
14	9785573 RETAINING RING, EXT., 0.984 SHAFT
15	9786084 HANDLE, CRANK - 5925
16	9783505 SCREW FLAT HD SOC 1_4-20 X 5_8
17	9783994 Bumper, Recess
18	9780827 Screw, Truss Head, 1_4-20 X 3_4
19	9785423 Spacer, Round, RATCHET - 5925
20	9784628 WHEEL, CRANK HANDLE - 5025
21	9784629 BEARING, RADIAL BALL, DOUBLE SHIELDED
22	9784729 WASHER, SHIM 1_4
23	9784632 SCREW, BUTTON 1_4-20 X 1.75
24	9784629 BEARING, RADIAL BALL, DOUBLE SHIELDED
25	9785785 SCREW, FLAT HEAD SOC 5_16-18 X 2.00 LG
26	9785447 SPRING, EXTENSION 2.25 X .312 X .035
27	9785986 WASHER, BELLVILLE, .877 OD X .402 ID X .062 TH
28	9785539 PIVOT, RATCHET PAWL - 5925
29	9785396 PAWL, LEVER RATCHET LOCK - 5925
30	9785398 PAWL, SECONDARY RATCHET - 5925
31	9785448 SPRING, EXTENSION, RATCHET - 5925
32	9783483 Key, Square .125_5625
33	9785576 WASHER, FLAT M8 ZINC
34	9780182 Nut, Nylock 5_16-18
35	9785283 BUSHING, STEEL - 5025 CRANK HANDLE
36	9784846 SCREW, SET, TORX 1_4-28 X .375
37	6786165 Ratchet Assembly

**PART NUMBERS LISTED MAY ONLY BE AVAILABLE IN KIT FORM OR AS AN ASSEMBLY**

Exploded Views, Continued..

...Exploded Views, Continued

### 8.8 Shroud

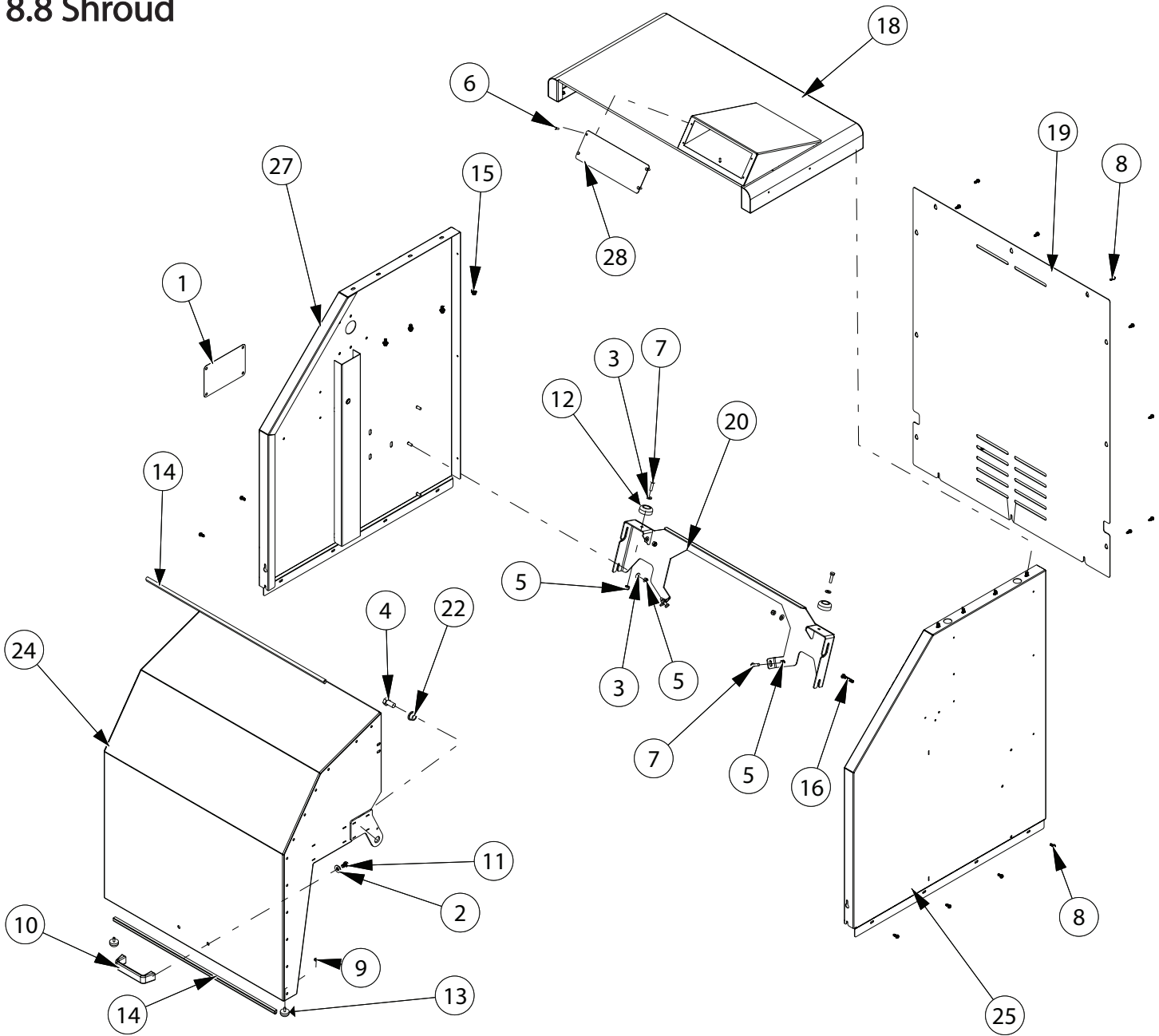

ID	Description
1	1787056 NAMEPLATE, METAL - 5925X1
2	9100023 WASHER, FLAT 5_16 USS
3	9760514 Washer 1_4 SAE .281 ID
4	9780221 SCREW HEX 1_2-13 X 1.00
5	9780343 Nut 1_4-20 Nylon Lock
6	9781367 Screw Hex Thd Form #8 X .50
7	9781831 Screw, Hex 1_4 X 1
8	9780366 Screw, #10-32 SHWH Tap
9	9783426 Nut, Keps #10-32
10	9783987 Handle, Door - 5025
11	9783988 Screw Hex 5_16-18 X .50
12	9783994 Bumper, Recess
13	9785137 BUMPER, RUBBER - THREADED STUD

ID	Description
14	9785773 SEAL, DOOR - 5925
15	9785779 SCREW, SERRATED FLANGE HEX HD, .25-20 X .50 LG
16	9785786 SCREW, HEX CAP 1_4-20 X 1.50 FULL THD
18	9786698 PANEL, TOP, 5025-5925
19	9786699 PANEL, BACK, 5025 - 5925
20	9786722 STOP, DOOR, ONE PIECE - 5925-5025
22	9786732 BEARING, BRONZE, FLANGED, .50 ID
24	9786734 DOOR WELDMENT - 5925-5025
25	9786736 PANEL, SIDE, RIGHT - 5925-5025
27	9786841 PANEL, SIDE, LEFT - 5925-5025 EX PROOF
28	9786848 COVER PLATE, 5025X1-5925X1

**PART NUMBERS LISTED MAY ONLY BE AVAILABLE IN KIT FORM OR AS AN ASSEMBLY**

Exploded Views, Continued..

...Exploded Views, Continued

### 8.9 Riser Kit X1U

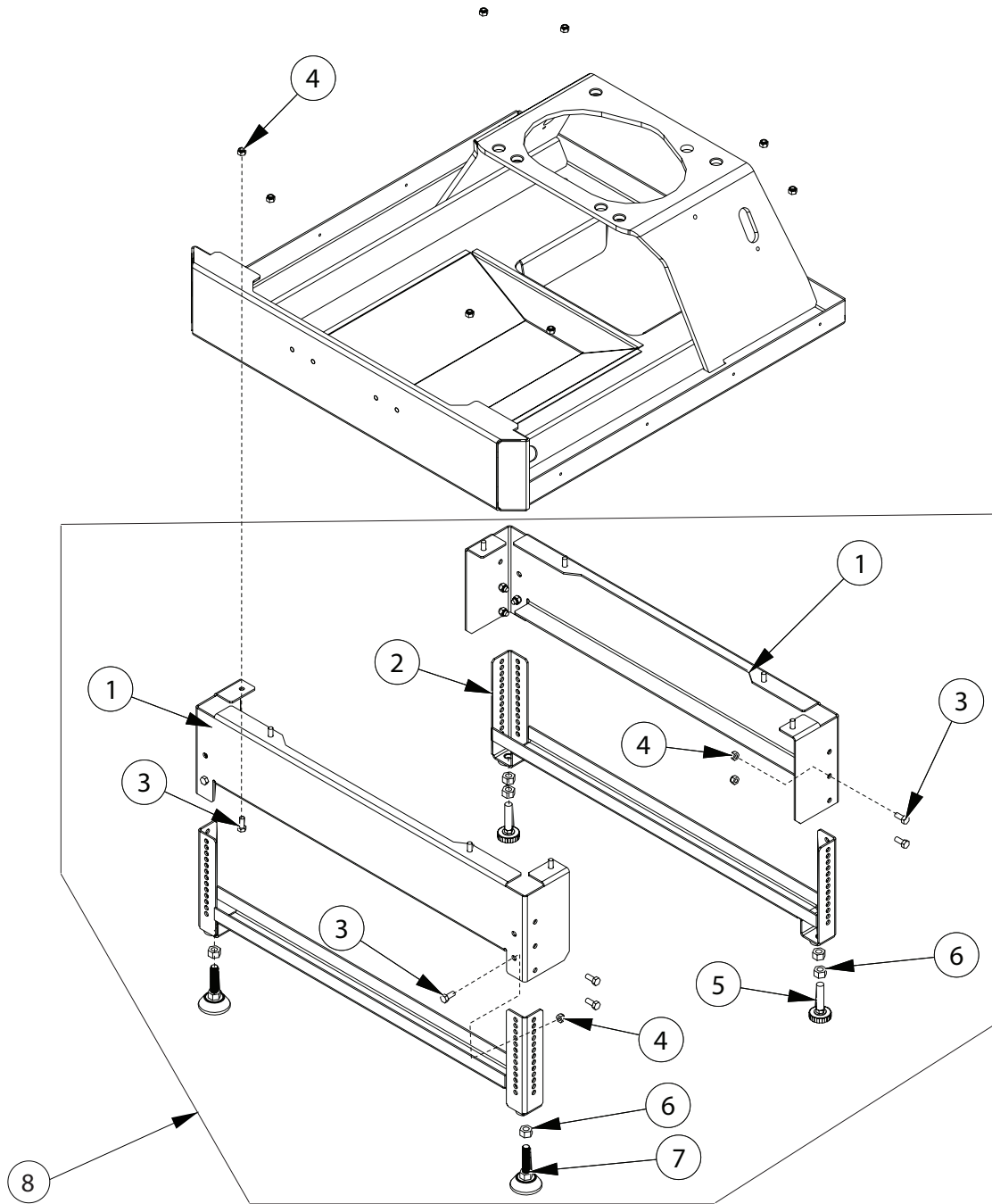

ID	Description
1	9786767 RISER, UNIVERSAL RR - 5025 - 5925
2	9786766 LEG, CROSSBAR, UNIVERSAL RR - 5025 - 5925
3	9782407 Screw Hex 5_16 X 3_4
4	9780182 Nut, Nylock 5_16-18
5	9785721 FOOT, GLIDER - 1_2-13
6	9781711 NUT, 1_2-13
7	9785722 FOOT, NON SKID, LEVELING - 1_2-13
8	6786807 Kit Riser

**PART NUMBERS LISTED MAY ONLY BE AVAILABLE IN KIT FORM OR AS AN ASSEMBLY**

Exploded Views, Continued..

...Exploded Views, Continued

### 8.10 Feet X1

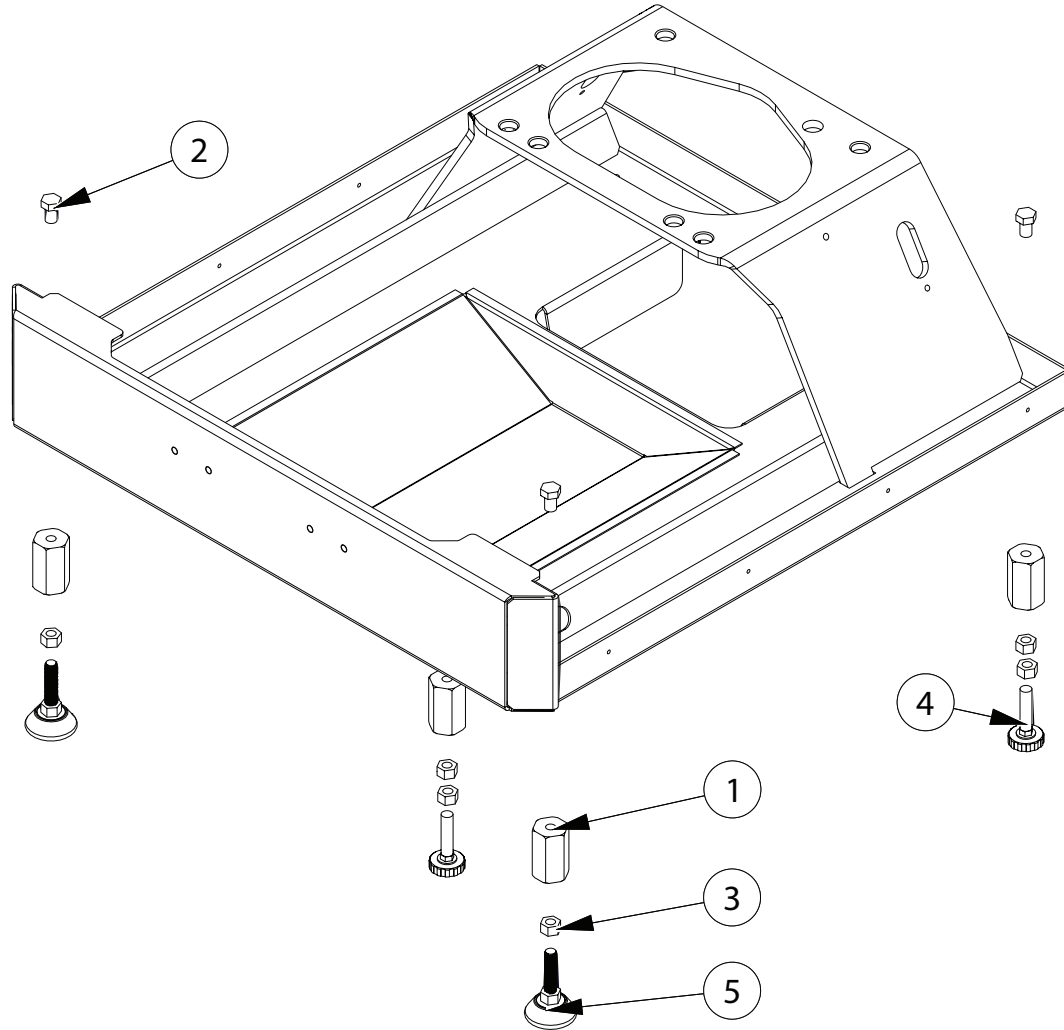

ID	Description
1	9786765 RISER, HEX, FLOOR - 5025 - 5925
2	9785862 SCREW HEX 1_2-13 X .75 LG
3	9781711 NUT, 1_2-13
4	9785721 FOOT, GLIDER - 1_2-13
5	9785722 FOOT, NON SKID, LEVELING - 1_2-13

**PART NUMBERS LISTED MAY ONLY BE AVAILABLE IN KIT FORM OR AS AN ASSEMBLY**

Exploded Views, Continued..

...Exploded Views, Continued

### 8.11 Electrical Exploded View

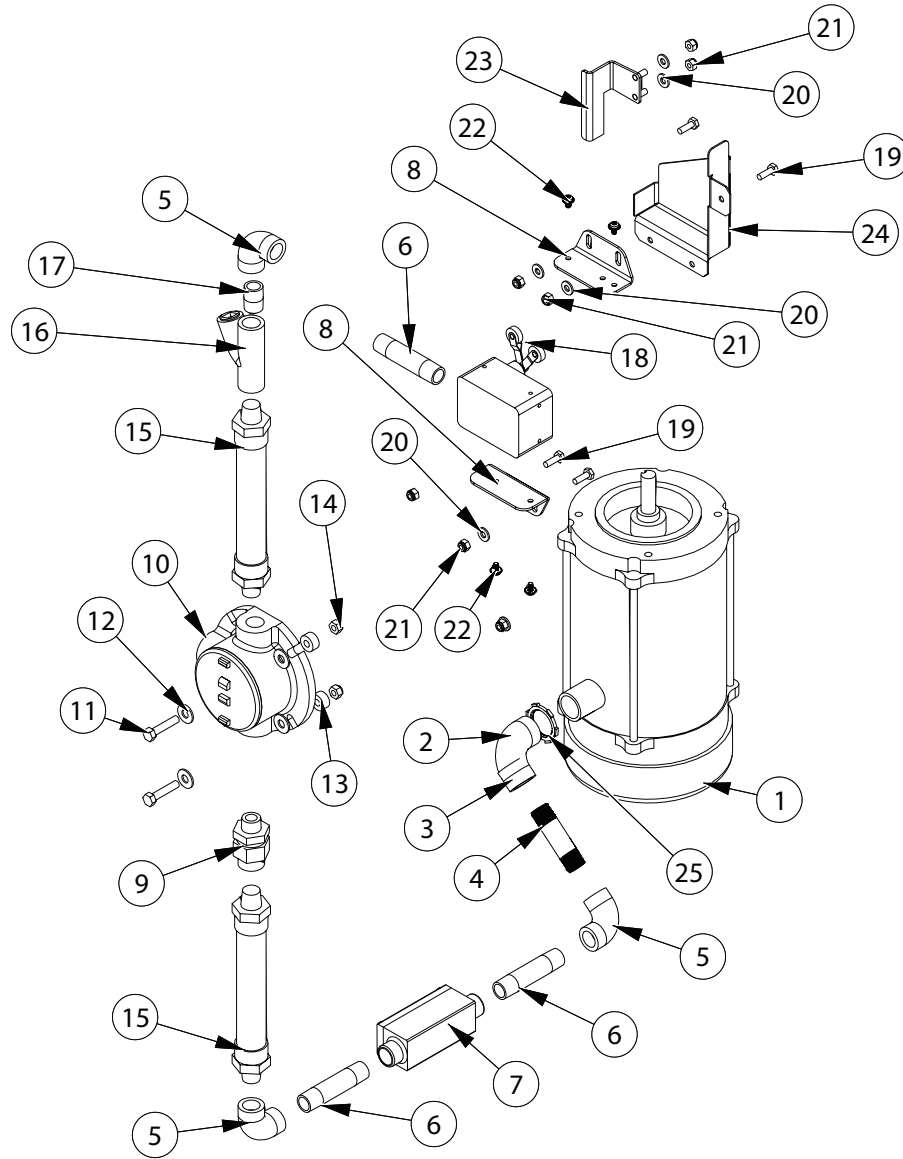

ID	Description
1	5786182 motor, x-proof, 1 hp, 56c
2	9786840 ELBOW, 90, F-F, 1 NPT
3	9786837 REDUCER, CONDUIT, 1.0-.50
4	9785154 NIPPLE, .50NPT X 3.00
5	9784116 Elbow, 90, .5 NPT, female-female
6	9786843 NIPPLE, 1_2 NPT X 3.50
7	9786836 CONDUIT BODY, C - .50 NPT
8	9784124 bracket, limit switch
9	9782429 UNION, .5 NPT
10	9784067 Conduit Box, T 0.50
11	9780775 Screw Hex 5_16 X 1.50
12	9100023 WASHER, FLAT 5_16 USS
13	9784142 Spacer, .315ID x .750OD x .375 Long

ID	Description
14	9780182 Nut, Nylock 5_16-18
15	9784117 Conduit, Flexible - .5 NPT, 6 Long
16	9784068 Fitting, Seal 0.50 M-F
17	9784115 Nipple, Close - .5 NPT
18	5784065 Switch, Limit Explosion Proof - 20A Rating
19	9159200 SCREW HEX 1_4-20 X .75
20	9760514 Washer 1_4 SAE .281 ID
21	9780343 Nut 1_4-20 Nylon Lock
22	9784079 Screw, Machine Washer HD #10-32 x .375
23	9786838 BRACKET, TRIP, LIMIT SWITCH
24	9786842 COVER, SWITCH, 5025 EX PROOF
25	9787290 CONDUIT LOCKNUT, 1.00

**PART NUMBERS LISTED MAY ONLY BE AVAILABLE IN KIT FORM OR AS AN ASSEMBLY**



## 9. Ordering

### Replacment Parts

#### HOW TO ORDER REPLACEMENT PARTS

Replacement parts can be ordered from Radia by telephone, fax, or email:

#### **RADIA**

800-221-1083  
763-533-2969  
763-533-0015 (FAX)  
orders@radiaproducts.com

If you need help in determining the proper part(s) to order, please call Customer Care. at 1-800-221-1083. Always indicate the Model and Serial numbers of the machine when ordering replacement parts.

#### GENERAL PARTS REPLACEMENT POLICIES

While your machine is under warranty, do not attempt on-site repair or parts replacement without first contacting RADIA. (to protect your warranty). After the warranty expires, replacement parts and recommendations for on-site servicing are available from RADIA. Please contact Customer Care for assistance.

#### RESTOCKING FEE

A restocking fee will be charged on all unused parts which are returned.



For instructional "How To" videos please visit:  
[www.radiaproducts.com](http://www.radiaproducts.com)





## 10. Warranty

### Equipment Covered Under This Warranty

#### Models 0-5925-X1 & X1U

Radia warrants equipment manufactured by it and bearing its name to be free from defects in material and workmanship.

**EXCEPT FOR THE WARRANTY SET FORTH HEREIN, RADIA MAKES NO WARRANTY WHATSOEVER WITH RESPECT TO THE EQUIPMENT, INCLUDING ANY (a) WARRANTY OF MERCHANTABILITY; (b) WARRANTY OF FITNESS FOR A PARTICULAR PURPOSE; OR (c) WARRANTY AGAINST INFRINGEMENT OF INTELLECTUAL PROPERTY RIGHTS OF A THIRD PARTY; WHETHER EXPRESS OR IMPLIED BY LAW, COURSE OF DEALING, COURSE OF PERFORMANCE, USAGE OF TRADE OR OTHERWISE.**

This warranty applies only when the equipment is installed, operated and maintained in accordance with written Radia instructions as appearing in the owners' manuals.

This warranty does not cover, and Radia shall not be liable for, any malfunction, damage, or wear caused by faulty installation, misapplication, abrasion, corrosion, inadequate or improper maintenance, negligence, accident, tampering or substitution of non-Radia component parts, modification or use for non-intended purposes. Nor shall Radia be liable for malfunction, damage or wear caused by the incompatibility of Radia equipment with structures, accessories, equipment, or materials not supplied by Radia.

Subject to the limitations set forth above, Radia shall (i) repair or replace the equipment (or the defective part) or (ii) credit or refund the price of such equipment. Costs of labor and transportation for service of machines under this warranty will also be covered during the warranty period if Radia elects to repair or replace the equipment. Normal ground freight will be covered for replacement parts sent within the warranty period. For customers outside of the US and Canada, the warranty is for parts only. Ground or common carrier ground freight will be covered for the return of defective items only. In no case shall Radia's liability exceed the amount of the purchase price.

\*All warranty repairs must be executed by a Radia Authorized Service Center or warranty will be voided.

**THE REMEDIES SET FORTH HEREIN ARE PURCHASER'S SOLE AND EXCLUSIVE REMEDY and RADIA'S ENTIRE LIABILITY FOR ANY BREACH OF THE LIMITED WARRANTY SET FORTH HEREIN.**

Please contact your Radia Relationship Manager at 800-221-1083 for specific questions regarding specific questions regarding warranty terms.





## For sales or service, please contact

RADIA  
Attn: Customer Service Department  
14900 21st Ave N  
Plymouth, Mn 55447  
USA

**U.S. Telephone:** 800.221.1083  
**International Telephone:** 763.533.2969  
**Fax:** 763.533.0015  
**E-mail:** [info@radiaproducts.com](mailto:info@radiaproducts.com)

[www.radiaproducts.com](http://www.radiaproducts.com)



For instructional "How To" videos please visit:  
[www.radiaproducts.com](http://www.radiaproducts.com)

